

- Low triboelectric noise cable
- Screened coaxial cable
- PFA Jacket
- -90°C to +260°C range
- Ideal for Charge output sensors
- Blue jacket colour with Low Noise labelling
- Nominal diameter 2mm
- 10/32UNF Microdot Connector/BNC Plug
- Length 3m±5%

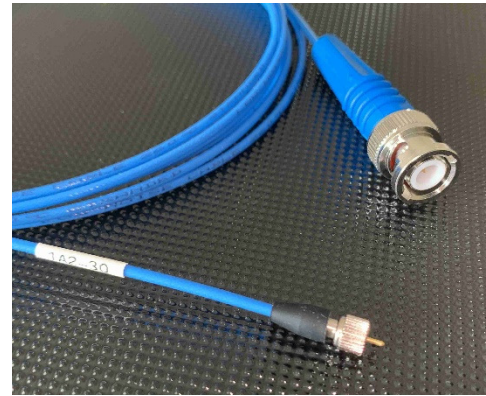

BNC Plug	
Electrical	Value
Impedance	50Ω
Frequency Range	0 ~ 3GHz
Working Voltage (max.)	500V max
Withstand Voltage	1500Vrms
Insulation Resistance	≥5000MΩ
VSWR (Voltage Standing Wave Ratio)	≤1.22
Physical	
Body	Nickel Plated Brass
Centre Conductor	Gold plated brass
Insulator	PTFE
Crimping body	Nickel plated copper alloy
Temperature Range	-55°C to +155°C
Durability	>500 connections

10/32UNF microdot connector	
Physical	Value
Body	Nickel Plated Brass
Knurl nut	Nickel Plated Brass
Centre Conductor	Gold plated brass
Insulator	PEEK
Strain relief boot	Rubber
Temperature Range	-90°C to +260°C

Cable Electrical Properties	Value
Impedance	50 ±2Ω
Max. Capacitance	105nF/km
Max. Conductor Resistance	355Ω/km
Min. Insulation Resistance	>5000 MΩ/km
Voltage rating	500VAC
Test voltage	3kV DC
Max. Attenuation	108dB/100m
Temp rating	-90°C to +260°C
Min Bending radius	Fixed: 10mm
Min Bending radius	Flexing: 20mm

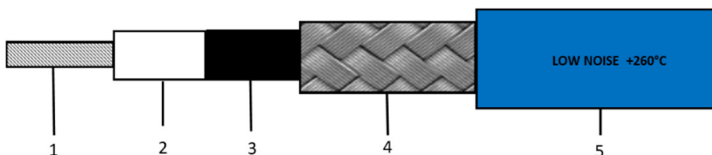

Layer	Description	Material	Overall diameter
1	Central conductor – multi strand	Silver plated high strength copper 30AWG (7/0.102mm)	0.30mm
2	Dielectric/Insulation	PTFE	0.85mm ±0.05mm
3	Low noise semi conductive coating		
4	Screen/Outer conductor	Silver Plated Copper Braid Greater than 96% coverage	1.56mm
5	Outer jacket	PFA	2mm nom.

Due to continued product development Kemo Limited reserve the right to change specification without notice.

- Low triboelectric noise cable
- Screened coaxial cable
- PFA Jacket
- -90°C to +260°C range
- Ideal for Charge output sensors
- Blue jacket colour with Low Noise labelling
- Nominal diameter 2mm
- 10/32UNF Microdot Connector/BNC Plug
- Length 5m±5%

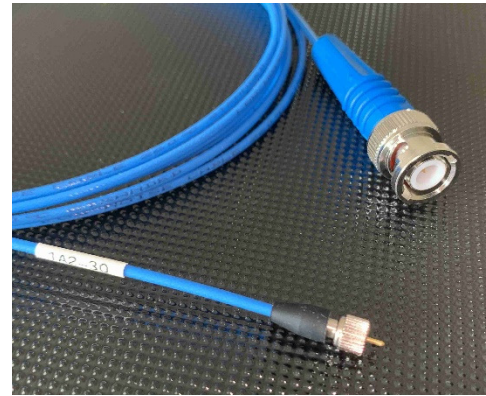

BNC Plug	
Electrical	Value
Impedance	50Ω
Frequency Range	0 ~ 3GHz
Working Voltage (max.)	500V max
Withstand Voltage	1500Vrms
Insulation Resistance	≥5000MΩ
VSWR (Voltage Standing Wave Ratio)	≤1.22
Physical	
Body	Nickel Plated Brass
Centre Conductor	Gold plated brass
Insulator	PTFE
Crimping body	Nickel plated copper alloy
Temperature Range	-55°C to +155°C
Durability	>500 connections

10/32UNF microdot connector	
Physical	Value
Body	Nickel Plated Brass
Knurl nut	Nickel Plated Brass
Centre Conductor	Gold plated brass
Insulator	PEEK
Strain relief boot	Rubber
Temperature Range	-90°C to +260°C

Cable Electrical Properties	Value
Impedance	50 ±2Ω
Max. Capacitance	105nF/km
Max. Conductor Resistance	355Ω/km
Min. Insulation Resistance	>5000 MΩ/km
Voltage rating	500VAC
Test voltage	3kV DC
Max. Attenuation	108dB/100m
Temp rating	-90°C to +260°C
Min Bending radius	Fixed: 10mm
Min Bending radius	Flexing: 20mm

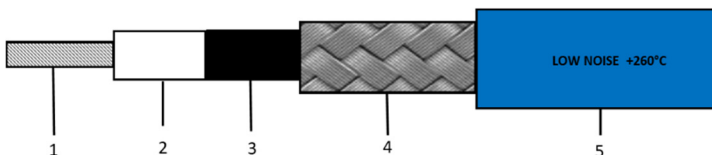

Layer	Description	Material	Overall diameter
1	Central conductor – multi strand	Silver plated high strength copper 30AWG (7/0.102mm)	0.30mm
2	Dielectric/Insulation	PTFE	0.85mm ±0.05mm
3	Low noise semi conductive coating		
4	Screen/Outer conductor	Silver Plated Copper Braid Greater than 96% coverage	1.56mm
5	Outer jacket	PFA	2mm nom.

Due to continued product development Kemo Limited reserve the right to change specification without notice.

- Screened coaxial IEPE sensor cable
- FEP Jacket
- -70°C to +200°C range
- Ideal for IEPE accelerometer sensors
- Black jacket colour
- Nominal diameter 1.9mm
- 10/32UNF Microdot Connector/BNC Plug
- Length 3m±5%



BNC Plug	
Electrical	Value
Impedance	50Ω
Frequency Range	0 ~ 3GHz
Working Voltage (max.)	500V max
Withstand Voltage	1500Vrms
Insulation Resistance	≥5000MΩ
VSWR (Voltage Standing Wave Ratio)	≤1.22
Physical	
Body	Nickel Plated Brass
Centre Conductor	Gold plated brass
Insulator	PTFE
Crimping body	Nickel plated copper alloy
Temperature Range	-55°C to +155°C
Durability	>500 connections

10/32UNF microdot connector	
Physical	Value
Body	Nickel Plated Brass
Knurl nut	Nickel Plated Brass
Centre Conductor	Gold plated brass
Insulator	PEEK
Strain relief boot	Rubber
Temperature Range	-70°C to +260°C

Cable Electrical Properties	Value
Impedance	50 ±2Ω
Max. Capacitance	100nF/km
Max. Conductor Resistance	355Ω/km
Min. Insulation Resistance	>5000 MΩ/km
Voltage rating	500VAC
Test voltage	3kV DC
Max. Attenuation	108dB/100m
Temp rating	-70°C to +200°C
Min Bending radius	Fixed: 10mm
Min Bending radius	Flexing: 20mm

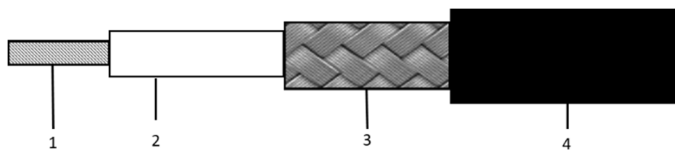

Layer	Description	Material	Overall diameter
1	Central conductor – multi strand	Silver plated copper clad steel 30AWG (7/0.102mm)	0.30mm
2	Dielectric/Insulation	PTFE	0.86mm ±0.05mm
3	Screen/Outer conductor	Silver Plated Copper Braid Greater than 96% coverage	1.35mm
4	Outer jacket	FEP	1.9mm nom.

Due to continued product development Kemo Limited reserve the right to change specification without notice.

- Screened coaxial IEPE sensor cable
- FEP Jacket
- -70°C to +200°C range
- Ideal for IEPE accelerometer sensors
- Black jacket colour
- Nominal diameter 1.9mm
- 10/32UNF Microdot Connector/BNC Plug
- Length 5m±5%



BNC Plug	
Electrical	Value
Impedance	50Ω
Frequency Range	0 ~ 3GHz
Working Voltage (max.)	500V max
Withstand Voltage	1500Vrms
Insulation Resistance	≥5000MΩ
VSWR (Voltage Standing Wave Ratio)	≤1.22
Physical	
Body	Nickel Plated Brass
Centre Conductor	Gold plated brass
Insulator	PTFE
Crimping body	Nickel plated copper alloy
Temperature Range	-55°C to +155°C
Durability	>500 connections

10/32UNF microdot connector	
Physical	Value
Body	Nickel Plated Brass
Knurl nut	Nickel Plated Brass
Centre Conductor	Gold plated brass
Insulator	PEEK
Strain relief boot	Rubber
Temperature Range	-70°C to +260°C

Cable Electrical Properties	Value
Impedance	50 ±2Ω
Max. Capacitance	100nF/km
Max. Conductor Resistance	355Ω/km
Min. Insulation Resistance	>5000 MΩ/km
Voltage rating	500VAC
Test voltage	3kV DC
Max. Attenuation	108dB/100m
Temp rating	-70°C to +200°C
Min Bending radius	Fixed: 10mm
Min Bending radius	Flexing: 20mm

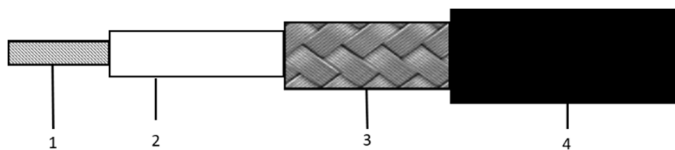

Layer	Description	Material	Overall diameter
1	Central conductor – multi strand	Silver plated copper clad steel 30AWG (7/0.102mm)	0.30mm
2	Dielectric/Insulation	PTFE	0.86mm ±0.05mm
3	Screen/Outer conductor	Silver Plated Copper Braid Greater than 96% coverage	1.35mm
4	Outer jacket	FEP	1.9mm nom.

Due to continued product development Kemo Limited reserve the right to change specification without notice.

- Low triboelectric noise cable
- Screened coaxial cable
- PFA Jacket
- -90°C to +260°C range
- Ideal for Piezoelectric charge output sensors
- Blue jacket colour with Low Noise labelling
- Nominal diameter 2mm
- 10/32UNF Microdot to 10/32UNF Microdot
- Length 3m±5%

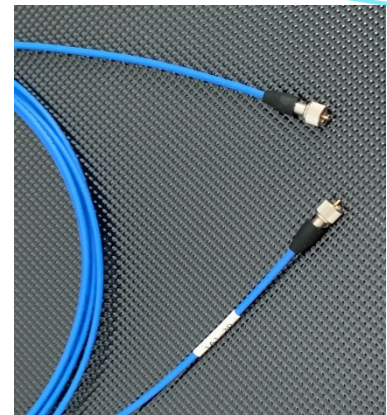

Kemo Ltd has been making high quality signal conditioning equipment since 1965 and during this time we have worked with many of the World's largest companies and witnessed many examples of poor quality instrumentation cables. To resolve this problem Kemo offers its own specialist cable assemblies for the sensor and instrumentation market.

The low noise cables we produce are assembled by Kemo using the highest quality cable and connectors that meet our exacting standards. Designed for use with piezoelectric sensors to minimise triboelectric noise, these cables also feature high screen coverage to reduce interference.

Attention is paid to strain relief and correct crimping. Every cable is fully tested and the capacitance checked prior to despatch.

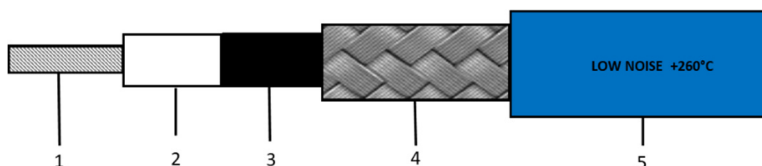

10/32UNF microdot connector	
Physical	Value
Body	Nickel Plated Brass
Knurl nut	Nickel Plated Brass
Centre Conductor	Gold plated brass
Insulator	PTFE
Strain relief boot	Rubber
Temperature Range	-90°C to +260°C

Cable Electrical Properties	Value
Impedance	50 ±2Ω
Max. Capacitance	105nF/km
Max. Conductor Resistance	355Ω/km
Min. Insulation Resistance	>5000 MΩ/km
Voltage rating	500VAC
Test voltage	3kV DC
Max. Attenuation	108dB/100m
Temp rating	-90°C to +260°C
Min Bending radius	Fixed: 10mm
Min Bending radius	Flexing: 20mm

Layer	Description	Material	Overall diameter
1	Central conductor – multi strand	Silver plated high strength copper 30AWG (7/0.102mm)	0.30mm
2	Dielectric/Insulation	PTFE	0.85mm ±0.05mm
3	Low noise semi conductive coating		
4	Screen/Outer conductor	Silver Plated Copper Braid Greater than 96% coverage	1.6mm
5	Outer jacket	PFA	2mm nom.

Due to continued product development Kemo Limited reserve the right to change specification without notice.

- Low triboelectric noise cable
- Screened coaxial cable
- PFA Jacket
- -90°C to +260°C range
- Ideal for Piezoelectric charge output sensors
- Blue jacket colour with Low Noise labelling
- Nominal diameter 2mm
- 10/32UNF Microdot to 10/32UNF Microdot
- Length 5m±5%

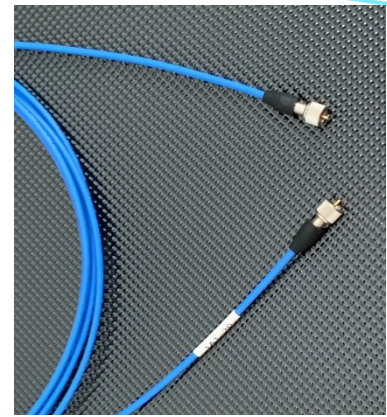

Kemo Ltd has been making high quality signal conditioning equipment since 1965 and during this time we have worked with many of the World's largest companies and witnessed many examples of poor quality instrumentation cables. To resolve this problem Kemo offers its own specialist cable assemblies for the sensor and instrumentation market.

The low noise cables we produce are assembled by Kemo using the highest quality cable and connectors that meet our exacting standards. Designed for use with piezoelectric sensors to minimise triboelectric noise, these cables also feature high screen coverage to reduce interference.

Attention is paid to strain relief and correct crimping. Every cable is fully tested and the capacitance checked prior to despatch.

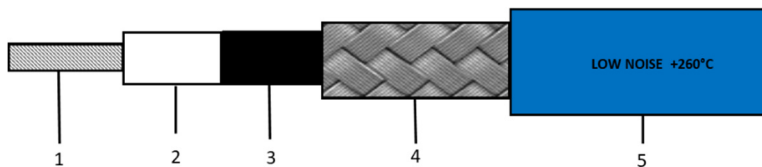

10/32UNF microdot connector	
Physical	Value
Body	Nickel Plated Brass
Knurl nut	Nickel Plated Brass
Centre Conductor	Gold plated brass
Insulator	PTFE
Strain relief boot	Rubber
Temperature Range	-90°C to +260°C

Cable Electrical Properties	Value
Impedance	50 ±2Ω
Max. Capacitance	105nF/km
Max. Conductor Resistance	355Ω/km
Min. Insulation Resistance	>5000 MΩ/km
Voltage rating	500VAC
Test voltage	3kV DC
Max. Attenuation	108dB/100m
Temp rating	-90°C to +260°C
Min Bending radius	Fixed: 10mm
Min Bending radius	Flexing: 20mm

Layer	Description	Material	Overall diameter
1	Central conductor – multi strand	Silver plated high strength copper 30AWG (7/0.102mm)	0.30mm
2	Dielectric/Insulation	PTFE	0.85mm ±0.05mm
3	Low noise semi conductive coating		
4	Screen/Outer conductor	Silver Plated Copper Braid Greater than 96% coverage	1.6mm
5	Outer jacket	PFA	2mm nom.

Due to continued product development Kemo Limited reserve the right to change specification without notice.

- Screened coaxial IEPE sensor cable
- FEP Jacket
- -70°C to +200°C range
- Ideal for IEPE accelerometer sensors
- Black jacket colour
- Nominal diameter 1.9mm
- 10/32UNF Microdot to 10/32UNF Microdot
- Length 3m±5%



Kemo Ltd has been making high quality signal conditioning equipment since 1965 and during this time we have worked with many of the World's largest companies and witnessed many examples of poor quality instrumentation cables. To resolve this problem Kemo offers its own specialist cable assemblies for the sensor and instrumentation market.

The cables we produce are assembled by Kemo using the highest quality cable and connectors that meet our exacting standards.

Attention is paid to strain relief and correct crimping. Every cable is fully tested and the capacitance checked prior to despatch.

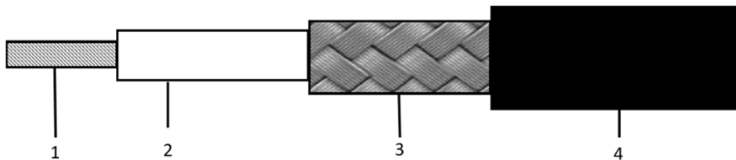

10/32UNF microdot connector	
Physical	Value
Body	Nickel Plated Brass
Knurl nut	Nickel Plated Brass
Centre Conductor	Gold plated brass
Insulator	PTFE
Strain relief boot	Rubber
Temperature Range	-70°C to +260°C

Cable Electrical Properties	Value
Impedance	50 ±2Ω
Max. Capacitance	100nF/km
Max. Conductor Resistance	355Ω/km
Min. Insulation Resistance	>5000 MΩ/km
Voltage rating	500VAC
Test voltage	3kV DC
Max. Attenuation	108dB/100m
Temp rating	-70°C to +200°C
Min Bending radius	Fixed: 10mm
Min Bending radius	Flexing: 20mm

Layer	Description	Material	Overall diameter
1	Central conductor – multi strand	Silver plated copper clad steel 30AWG (7/0.102mm)	0.30mm
2	Dielectric/Insulation	PTFE	0.86mm ±0.05mm
3	Screen/Outer conductor	Silver Plated Copper Braid Greater than 96% coverage	1.35mm
4	Outer jacket	FEP	1.9mm nom.

Due to continued product development Kemo Limited reserve the right to change specification without notice.

- Screened coaxial IEPE sensor cable
- FEP Jacket
- -70°C to +200°C range
- Ideal for IEPE accelerometer sensors
- Black jacket colour
- Nominal diameter 1.9mm
- 10/32UNF Microdot to 10/32UNF Microdot
- Length 5m±5%



Kemo Ltd has been making high quality signal conditioning equipment since 1965 and during this time we have worked with many of the World's largest companies and witnessed many examples of poor quality instrumentation cables. To resolve this problem Kemo offers its own specialist cable assemblies for the sensor and instrumentation market.

The cables we produce are assembled by Kemo using the highest quality cable and connectors that meet our exacting standards.

Attention is paid to strain relief and correct crimping. Every cable is fully tested and the capacitance checked prior to despatch.

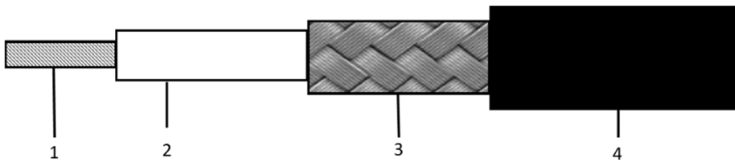

10/32UNF microdot connector	
Physical	Value
Body	Nickel Plated Brass
Knurl nut	Nickel Plated Brass
Centre Conductor	Gold plated brass
Insulator	PTFE
Strain relief boot	Rubber
Temperature Range	-70°C to +260°C

Cable Electrical Properties	Value
Impedance	50 ±2Ω
Max. Capacitance	100nF/km
Max. Conductor Resistance	355Ω/km
Min. Insulation Resistance	>5000 MΩ/km
Voltage rating	500VAC
Test voltage	3kV DC
Max. Attenuation	108dB/100m
Temp rating	-70°C to +200°C
Min Bending radius	Fixed: 10mm
Min Bending radius	Flexing: 20mm

Layer	Description	Material	Overall diameter
1	Central conductor – multi strand	Silver plated copper clad steel 30AWG (7/0.102mm)	0.30mm
2	Dielectric/Insulation	PTFE	0.86mm ±0.05mm
3	Screen/Outer conductor	Silver Plated Copper Braid Greater than 96% coverage	1.35mm
4	Outer jacket	FEP	1.9mm nom.

Due to continued product development Kemo Limited reserve the right to change specification without notice.

COLOURS Make it easy!!

- Available for Low triboelectric noise cable
- Available for IEPE screened coaxial cable
- Coloured Boots
- Matching coloured heat shrink
- Numbering also available
- Colour Combinations create unlimited options

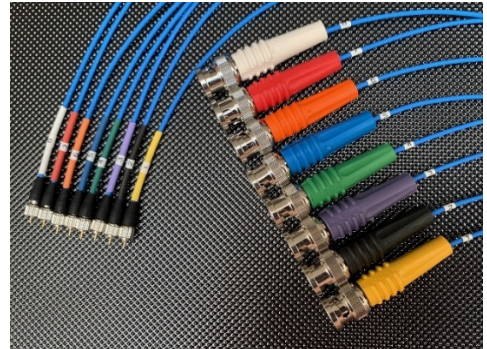

With decades of test experience under our belt we recognise there are some aspects of testing that seem very basic but can make a huge difference to the test experience.

One of these is cable identification, the more visual the better!!

Modern testing systems have many channels, sometimes hundreds, so identification of cables connected to specific channels at the data acquisition end can be tricky, particularly if cable lengths are more than a few metres.

Kemo offer a unique coloured identification system which can be combined for higher channel count solutions, this makes channel identification quick, simple and highly visual, reducing the risk of errors.

The coloured system can be supported with numbers and/or X, Y, Z if you want to identify directional axes information for use with triaxial accelerometers.

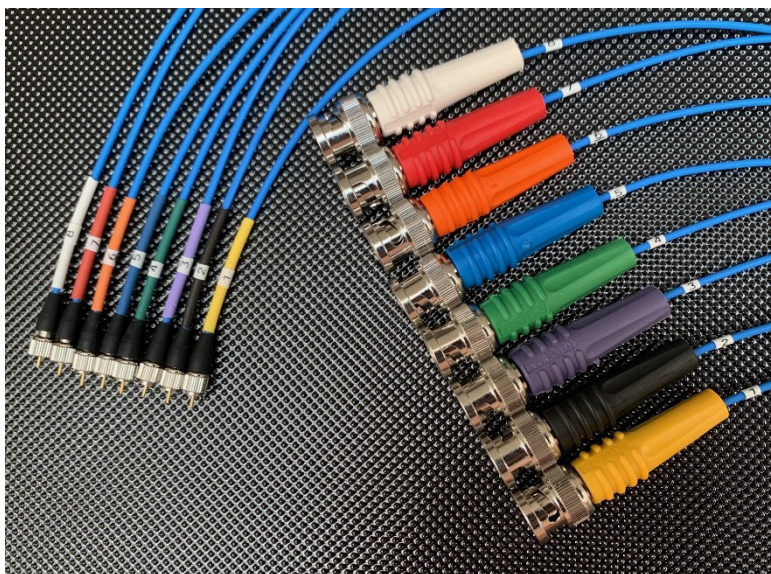

Cables can be supplied with a wide range of connectors:

- 10/32UNF Microdot Plug
- 10/32UNF Socket
- M5 Microdot Plug
- BNC Plug
- BNC Socket.
- SMA
- SMB
- SMC
- Lemo®

Contact us for how we can help
sales@kemo.com
+44(0)1474 705168

Due to continued product development Kemo Limited reserve the right to change specification without notice.

- Screened 4 core cable
- FEP Jacket
- -70°C to +200°C range
- Ideal for IEPE accelerometer sensors
- Black jacket colour
- Nominal diameter 2.2mm
- 1/4-28UNF 4 Pin Socket to 3 x BNC Plug
- Labels X, Y, Z
- Length 3m±5%

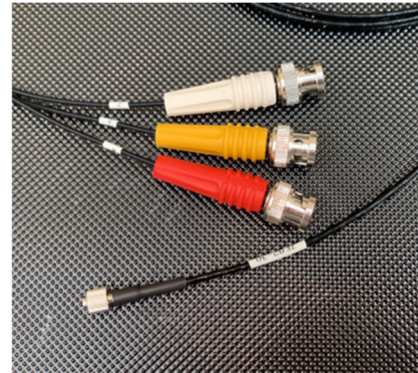

The 7F82-30 is a 3m cable assembly developed for use with a range of triaxial accelerometers that use a 1/4-28UNF threaded 4 pin connector. This connector is used on several of Kemo's own accelerometers as well as on a wide range of other competitor products.

Featuring a lightweight 4 core cable of just 2.2mm diameter which ensures minimal mass loading and return vibration effect on the miniature triaxial accelerometer connected to the cable assembly.

Other cable lengths are available, please enquire for stock availability.

These cables are also available with alternative terminating connectors, including:

- 10/32UNF or M5 microdot plugs/sockets
- SMA
- SMB
- BNC sockets



Due to continued product development Kemo Limited reserve the right to change specification without notice.

- Screened 4 core cable
- FEP Jacket
- -70°C to +200°C range
- Ideal for IEPE accelerometer sensors
- Black jacket colour
- Nominal diameter 2.2mm
- 1/4-28UNF 4 Pin Socket to 3 x BNC Plug
- Labels X, Y, Z
- Length 5m±5%

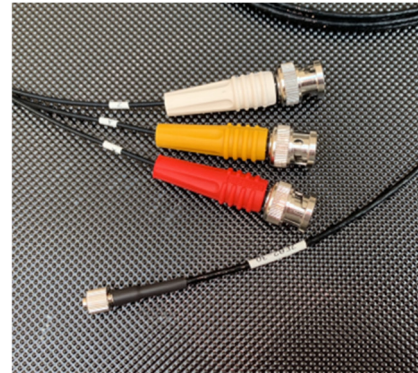

The 7F82-50 is a 5m cable assembly developed for use with a range of triaxial accelerometers that use a 1/4-28UNF threaded 4 pin connector. This connector is used on several of Kemo's own accelerometers as well as on a wide range of other competitor products.

Featuring a lightweight 4 core cable of just 2.2mm diameter which ensures minimal mass loading and return vibration effect on the miniature triaxial accelerometer connected to the cable assembly.

Other cable lengths are available, please enquire for stock availability.

These cables are also available with alternative terminating connectors, including:

- 10/32UNF or M5 microdot plugs/sockets
- SMA
- SMB
- BNC sockets



Due to continued product development Kemo Limited reserve the right to change specification without notice.

- Screened 4 core cable
- FEP Jacket
- -50°C to +200°C range
- Ideal for IEPE accelerometer sensors
- Blue jacket colour
- Nominal diameter 2mm
- 8-36 to 3 x BNC Plug
- Length 3m±5%

The 12F82-30 is a 3m compatible cable assembly developed for use with a range of triaxial accelerometers that use a miniature 8-36 threaded 4 pin connector.

This cable suits the MVT10S-T and the MVT100S-T from the Kemo range of IEPE sensors.

It is also compatible with a range of triaxial sensors from other suppliers.

Featuring a lightweight 4 core cable of just 2mm diameter which ensures minimal mass loading and return vibration effect on the miniature triaxial accelerometer connected to the cable assembly.

Other cable lengths are available, please enquire for stock availability.

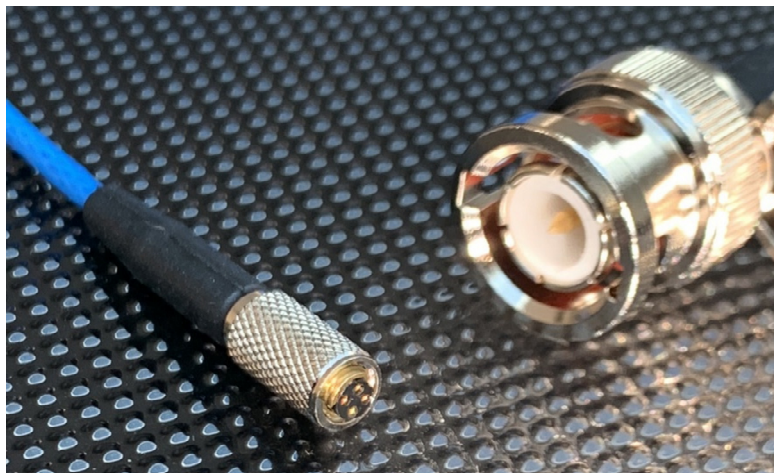
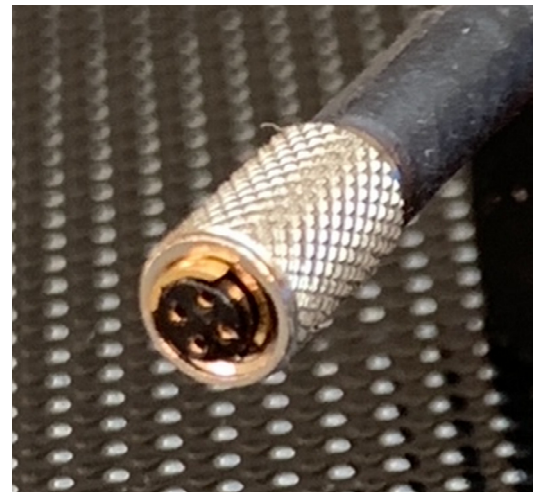
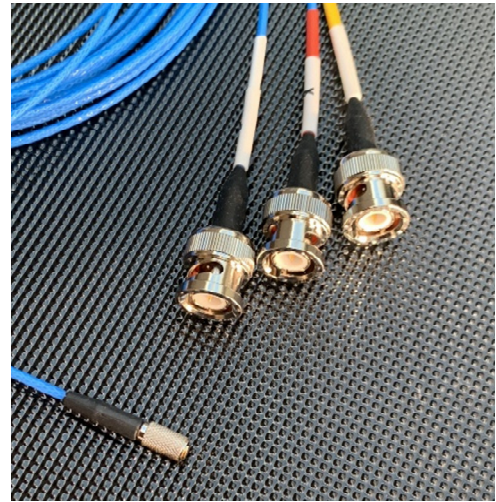

Due to continued product development Kemo Limited reserve the right to change specification without notice.

- Screened 4 core cable
- FEP Jacket
- -50°C to +200°C range
- Ideal for IEPE accelerometer sensors
- Blue jacket colour
- Nominal diameter 2mm
- 8-36 to 3 x BNC Plug
- Length 5m±5%

The 12F82-50 is a 5m compatible cable assembly developed for use with a range of triaxial accelerometers that use a miniature 8-36 threaded 4 pin connector.

This cable suits the MVT10S-T and the MVT100S-T from the Kemo range of IEPE sensors.

It is also compatible with a range of triaxial sensors from other suppliers.

Featuring a lightweight 4 core cable of just 2mm diameter which ensures minimal mass loading and return vibration effect on the miniature triaxial accelerometer connected to the cable assembly.

Other cable lengths are available, please enquire for stock availability.

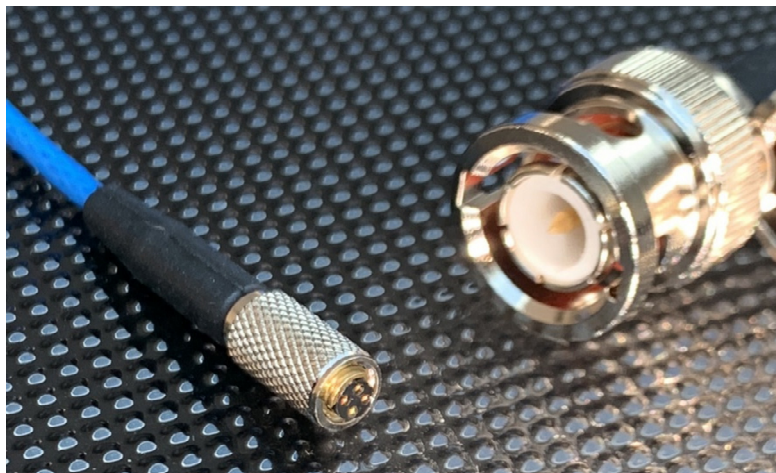
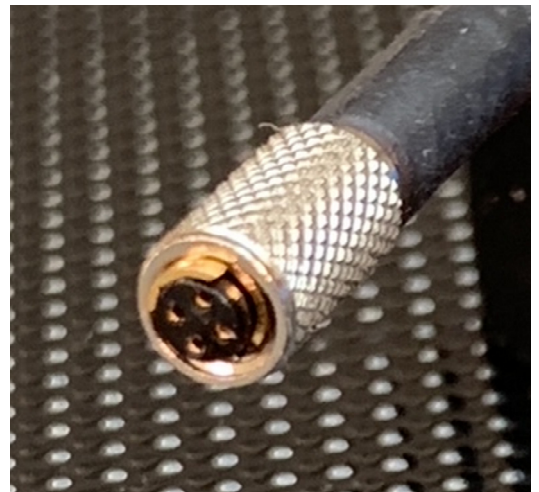
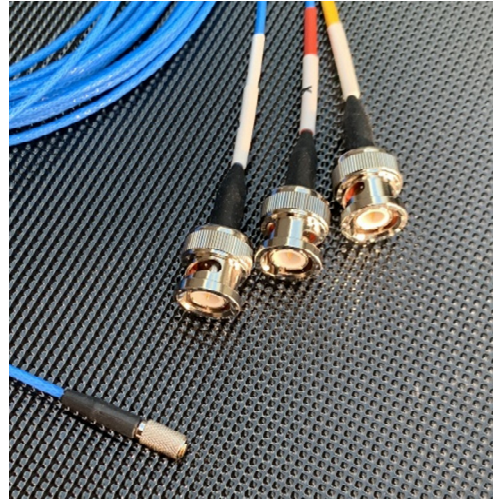

Due to continued product development Kemo Limited reserve the right to change specification without notice.

- Screened 4 core cable
- FEP Jacket
- -50°C to +200°C range
- Triaxial accelerometer connection
- Black jacket colour
- Nominal diameter 2.2mm
- 1/4-28UNF 4 Pin Socket
- Lemo® FGG.0B.309.CLAD32
- Lemo® GMA.0B.025.DN strain relief
- Length 5m±5%
- Other lengths available

The 7FL9-50 is a 5m cable assembly developed for use with a range of triaxial accelerometers that use a 1/4-28UNF threaded 4 pin connector. This cable assembly features a 9 pin Lemo® connector for direct connection to a number of OEM data acquisition and analysis systems. Using these cables removes the need for adaptor cables between the accelerometer and DAQ.

Featuring a lightweight 4 core cable of just 2.2mm diameter which ensures minimal mass loading and return vibration effect on the miniature triaxial accelerometer connected to the cable assembly.

Other cable lengths are available, please enquire for stock availability.



Lemo® is a registered trademark of Lemo S.A. Switzerland, only genuine Lemo products used.

Due to continued product development Kemo Limited reserve the right to change specification without notice.

- Screened 4 core cable
- FEP Jacket
- -50°C to +200°C range
- Ideal for IEPE accelerometer sensors
- Black jacket colour
- Nominal diameter 2.2mm
- 1/4-28UNF 4 Pin Socket to 3 x 10/32UNF Plugs
- Labels X, Y, Z
- Length 3m±5%

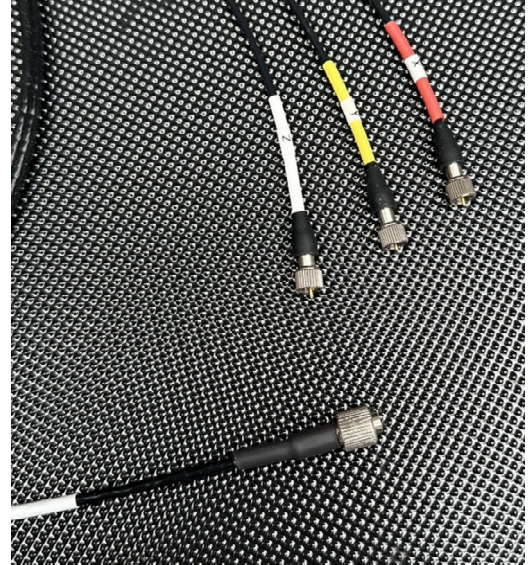

The 7F81-30 is a 3m cable assembly developed for use with a range of triaxial accelerometers that use a 1/4-28UNF threaded 4 pin connector. This connector is used on several of Kemo's own accelerometers as well as on a wide range of other competitor products.

The terminating connector is 3 x 10/32UNF microdot connectors labelled X, Y, Z

Featuring a lightweight 4 core cable of just 2.2mm diameter which ensures minimal mass loading and return vibration effect on the miniature triaxial accelerometer connected to the cable assembly.

Other cable lengths are available, please enquire for stock availability.

These cables are also available with alternative terminating connectors, including:

- BNC plugs
- SMA
- SMB
- BNC sockets



Due to continued product development Kemo Limited reserve the right to change specification without notice.

- Screened 4 core cable
- FEP Jacket
- -50°C to +200°C range
- Ideal for IEPE accelerometer sensors
- Black jacket colour
- Nominal diameter 2.2mm
- 1/4-28UNF 4 Pin Socket to 3 x 10/32UNF Plugs
- Labels X, Y, Z
- Length 5m±5%

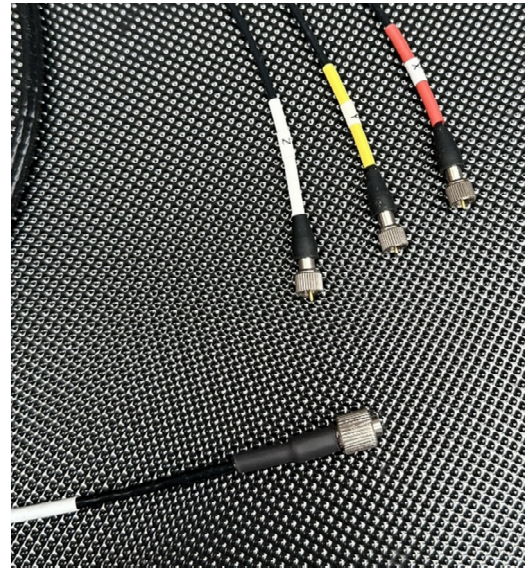

The 7F81-50 is a 5m cable assembly developed for use with a range of triaxial accelerometers that use a 1/4-28UNF threaded 4 pin connector. This connector is used on several of Kemo's own accelerometers as well as on a wide range of other competitor products.

The terminating connector is 3 x 10/32UNF microdot connectors labelled X, Y, Z

Featuring a lightweight 4 core cable of just 2.2mm diameter which ensures minimal mass loading and return vibration effect on the miniature triaxial accelerometer connected to the cable assembly.

Other cable lengths are available, please enquire for stock availability.

These cables are also available with alternative terminating connectors, including:

- BNC plugs
- SMA
- SMB
- BNC sockets



Due to continued product development Kemo Limited reserve the right to change specification without notice.

- Gold plated pin
- Nickel plated brass body
- Nickel plated brass knurl nut
- 10/32UNF plug
- Fitted by Kemo Ltd
- Rubber strain relief boot

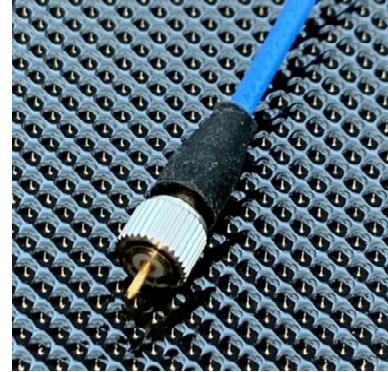

The 10/32UNF Microdot plug connector is industry standard in applications such as accelerometers, pressure sensors and other similar test and measurement sensors. Its compact size and secure thread fitting is well suited to sensor applications.

This KM-1 is fitted by Kemo to all of their cable assemblies requiring a 10/32UNF microdot connector.

Suitable for cables with a nominal diameter of 2mm.

Dimensions in mm

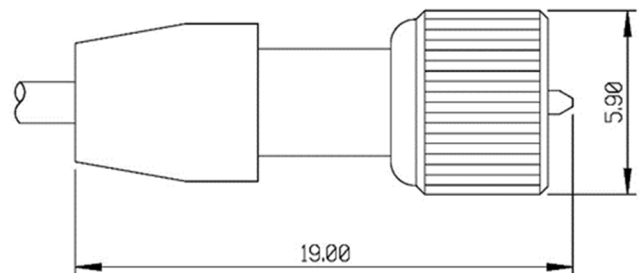

Variable	Value
Physical	
Body	Nickel Plated Brass
Knurl nut	Nickel Plated Brass
Centre Conductor	Gold plated brass
Insulator	PEEK
Strain relief boot	Rubber
Temperature Range	-70°C to +260°C

Due to continued product development Kemo Limited reserve the right to change specification without notice.

- Gold plated pin
- Nickel plated brass body
- Nickel plated brass knurl nut
- 10/32UNF right angle plug
- Fitted by Kemo Ltd
- Rubber strain relief boot



The 10/32UNF Right angle Microdot plug connector is industry standard in applications such as accelerometers, pressure sensors and other similar test and measurement sensors. Its compact size and secure thread fitting is well suited to sensor applications.

This KMR-1 is fitted by Kemo to all of their cable assemblies requiring a 10/32UNF right angle microdot connector.

Suitable for cables with a nominal diameter of 2mm.

Dimensions in mm

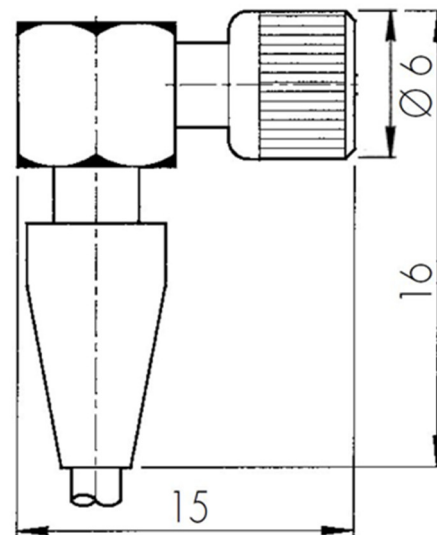

Variable	Value
Physical	
Body	Nickel Plated Brass
Knurl nut	Nickel Plated Brass
Centre Conductor	Gold plated brass
Insulator	PTFE
Strain relief boot	Rubber
Temperature Range	-70°C to +260°C

Due to continued product development Kemo Limited reserve the right to change specification without notice.

- Gold plated pin
- Nickel plated brass body
- Nickel plated brass knurl nut
- 10/32UNF socket
- Fitted by Kemo Ltd
- Rubber strain relief boot

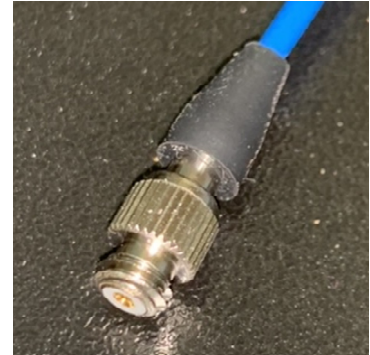

The 10/32UNF Microdot socket connector is industry standard in applications such as accelerometers, pressure sensors and other similar test and measurement sensors. The KMS-1 is used to provide an extension capability between cables.

This KMS-1 is fitted by Kemo to all of their cable assemblies requiring a 10/32UNF microdot socket connector.

Suitable for cables with a nominal diameter of 2mm.

Dimensions in mm

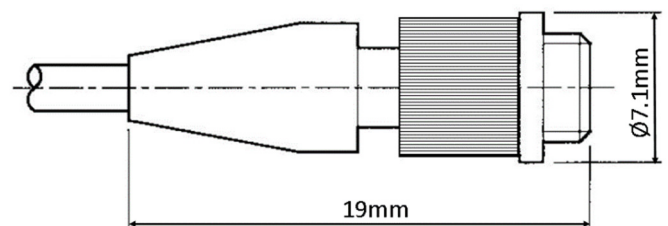

Variable	Value
Physical	
Body	Nickel Plated Brass
Knurl nut	Nickel Plated Brass
Centre Conductor	Gold plated brass
Insulator	PTFE
Strain relief boot	Rubber
Temperature Range	-70°C to +260°C

Due to continued product development Kemo Limited reserve the right to change specification without notice.

- Unique easy to fit design
- Gold plated pin
- Nickel plated body
- IEC60169-8
- CECC22120
- Crimp sleeve
- RG174 cable

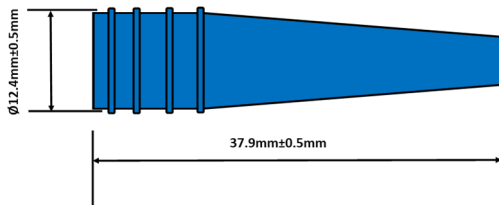
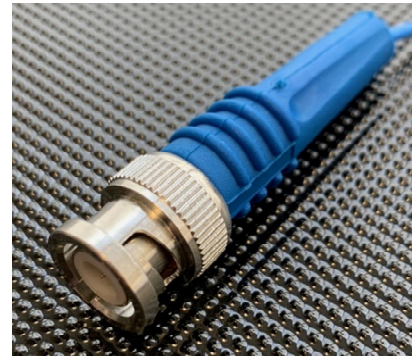

Dimensions in mm

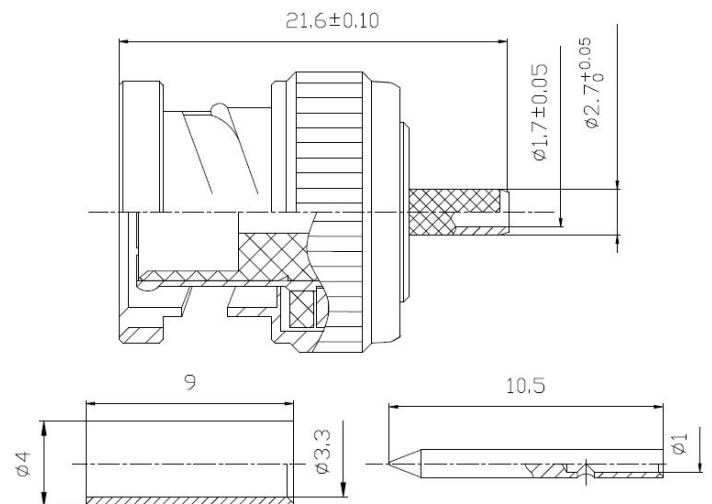

The KBNC-P is a high quality BNC crimp plug for RG174 cable

Used by Kemo Ltd as its primary BNC connector on all its cable assemblies, this connector can also be purchased as a self-fit connector to make your own cable assemblies.

Stock item

Variable	Value
Electrical	
Impedance	50 Ω
Frequency Range	0 ~ 3GHz
Working Voltage (max.)	500V max
Withstand Voltage	1500Vrms
Insulation Resistance	$\geq 5000\text{M}\Omega$
VSWR (Voltage Standing Wave Ratio)	≤ 1.22
Physical	
Body	Nickel Plated Brass
Centre Conductor	Gold plated brass
Insulator	PTFE
Crimping body	Nickel plated copper alloy
Temperature Range	-55°C to +155°C
Durability	>500 connections

- BNC Female Socket
- Gold plated pin
- Nickel plated body
- PTFE Insulator
- Crimp sleeve
- RG174 cable (approx. 2mm dia)
- EasyFit



Dimensions in mm

The KBNC-S is a high quality BNC crimp socket for RG174 cable

Used by Kemo Ltd as its primary BNC socket connector on all its cable assemblies, this connector can also be purchased as a self-fit connector to make your own cable assemblies.

Stock item

Note: Kemo strain relief boot not supplied in self fit kit, available as an option

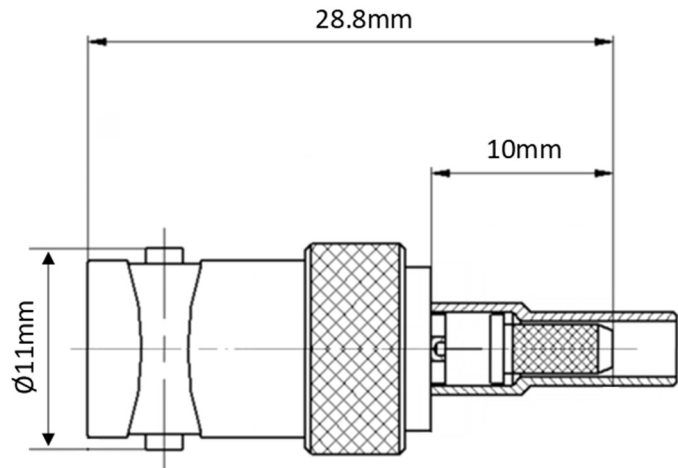

Variable	Value
Electrical	
Impedance	50Ω
Frequency Range	0 ~ 3GHz
Working Voltage (max.)	500V max
Withstand Voltage	1500Vrms
Insulation Resistance	≥5000MΩ
VSWR (Voltage Standing Wave Ratio)	≤1.22
Physical	
Body	Nickel Plated Brass
Centre Conductor	Gold plated brass
Insulator	PTFE
Crimping body	Nickel plated copper alloy
Temperature Range	-55°C to +125°C
Durability	>500 connections

Due to continued product development Kemo Limited reserve the right to change specification without notice.

- Gold plated pin
- Gold plated body
- SMA Male crimp connector
- Crimp sleeve also supplied
- Fitted by Kemo



The SMA Male connector is widely used in instrumentation and sensor connection applications.

This SMA male crimp connector for RG174 cable from Kemo Ltd. is used by Kemo on its cable assemblies that feature the SMA male plug connector.

It is a stock connector.

Select the correct Low noise or standard coaxial screened cable from Kemo stock also available with these connectors.

Dimensions in mm

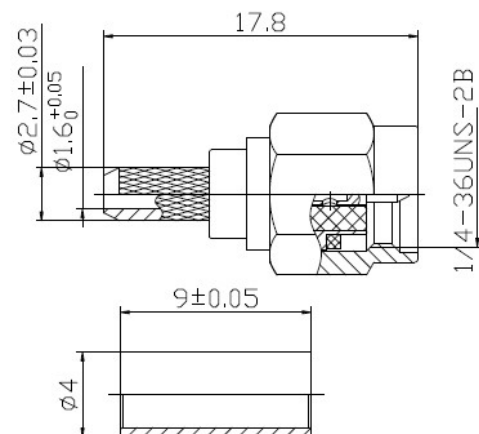

Variable	Value
Electrical	
Impedance	50Ω
Frequency Range	0 ~ 12.4GHz
Working Voltage (max.)	335V max
Withstand Voltage	1000Vrms
Insulation Resistance	≥5000MΩ
VSWR (Voltage Standing Wave Ratio)	≤1.1
Physical	
Body	Gold Plated Brass
Centre Conductor	Gold plated phosphor bronze
Insulator	PTFE
Temperature Range	-55°C to +155°C
Durability	>500 connections

Due to continued product development Kemo Limited reserve the right to change specification without notice.

- Gold plated pin
- Gold plated body
- SMB Female crimp connector
- Crimp sleeve also supplied
- Fitted by Kemo



The SMB female connector is widely used in instrumentation application, it is an ideal solution for instrument connections as it provides a quick fit.

This SMB female crimp connector for RG174 cable from Kemo Ltd. is used and fitted by Kemo on its cables.

Stock connector

Select the correct Low noise or standard coaxial screened cable from Kemo stock also available with these connectors.

Dimensions in mm

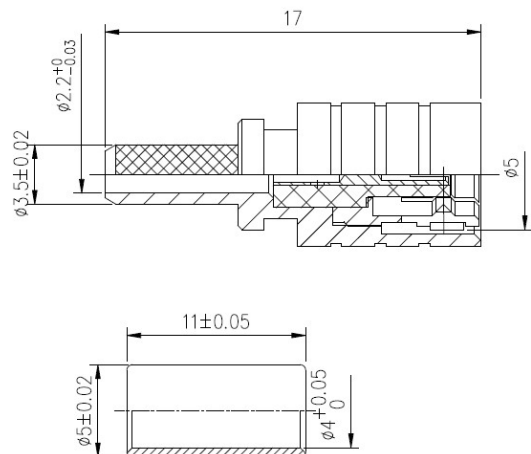

Variable	Value
Electrical	
Impedance	50Ω
Frequency Range	0 ~ 12.4GHz
Working Voltage (max.)	335V max
Withstand Voltage	1000Vrms
Insulation Resistance	≥5000MΩ
VSWR (Voltage Standing Wave Ratio)	≤1.2
Physical	
Body	Gold Plated Brass
Centre Conductor	Gold plated phosphor bronze
Insulator	PTFE
Temperature Range	-55°C to +155°C
Durability	>500 connections

Due to continued product development Kemo Limited reserve the right to change specification without notice.