

- General Purpose Piezoelectric Accelerometer
- Shear design
- Piezoelectric ceramic PZT-5
- Sensitivity – 30pC/g
- Mass – 12.5grams
- 10-32UNF top entry connector
- Use with a Low noise cable

The HGC30T-T is a high temperature general purpose monoaxial piezoelectric accelerometer with a top entry 10/32UNF microdot connector.

The base of the accelerometer has a tapped hole with a 10/32UNF thread for compatibility with many industry applications.

Featuring a shear design PZT-5 sensing element the HGC30T-T provides high accuracy up to 9kHz. Supplied with a standard 10/32UNF mounting stud (other studs are available on request).

Specification	Metric	Imperial
Sensitivity	3.06pC/(m/s <sup>2</sup> )	30pC/g
Measurement Range (pk)	±9800m/s <sup>2</sup>	±1000g
Frequency Range ±10%	9000 Hz	
Resonant Frequency	≥27 kHz	
Non-Linearity	≤1 %	
Transverse Sensitivity	≤5 %	
Overload Limit (Shock)	±24500(m/s <sup>2</sup> )pk	±2500gpk
Operating Temp. Range	-55 to +250°C	-67 to +482°F
Polarity ↑	Positive	
Capacitance	850 pF	
Insulation Resistance	>1X10 <sup>11</sup> Ω	
Size (excluding connector)	14(A/F)x23 mm	0.55"(A/F)x0.91"
Weight	12.5gm	0.44oz
Sensing Geometry	Shear	
Sensing Element Material	PZT-5	
Case Material	Titanium	
Connector Position	Top	
Case sealing	Welded	
Electrical Connection Type	10-32UNF Microdot	
Mounting Thread (tapped base)	10-32UNF	
Mounting Torque	3Nm	26in/lb

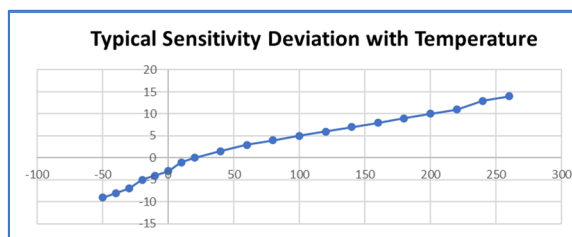
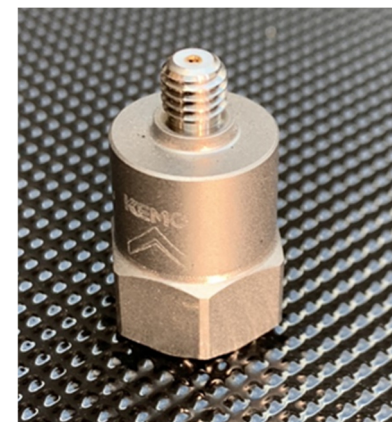
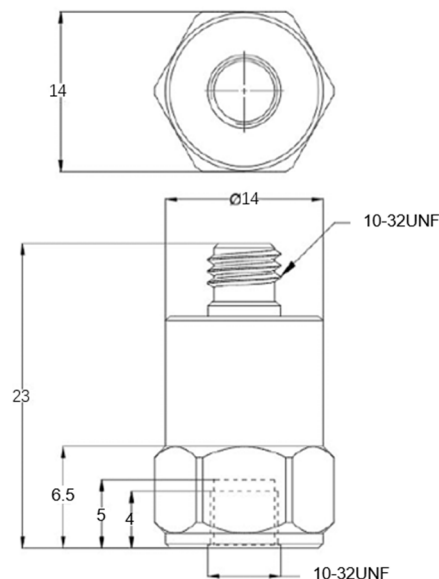

It is recommended that the HGC30T-T is used with a low noise cable from Kemo's range to reduce triboelectric noise.

- 1A2-30 – 3m(10ft) 10/32UNF microdot to BNC plug
- 1A2-50 – 5m(15ft) 10/32UNF microdot to BNC plug
- 1A1-30 – 3m(10ft) 10/32UNFmdot to 10/32UNFmdot
- 1A1-50 – 5m(15ft) 10/32UNFmdot to 10/32UNFmdot

- General Purpose Piezoelectric Accelerometer
- Shear design
- Piezoelectric ceramic PZT-5
- Sensitivity – 50pC/g
- Mass – 36grams
- 10-32UNF top entry connector
- Use with a Low noise cable

The HGC50T-T is a high temperature general purpose monoaxial piezoelectric accelerometer with a top entry 10/32UNF microdot connector.

The base of the accelerometer has a tapped hole with a 10/32UNF thread for compatibility with many industry applications.

Featuring a shear design PZT-5 sensing element the HGC30T-T provides high accuracy up to 6kHz  
Supplied with a standard 10/32UNF mounting stud (other studs are available on request).

Specification	Metric	Imperial
Sensitivity	5.09pC/(m/s <sup>2</sup> )	50pC/g
Measurement Range (pk)	±9800m/s <sup>2</sup>	±1000g
Frequency Range ±10%	0.5Hz to 6000 Hz	
Resonant Frequency	≥20 kHz	
Non-Linearity	≤1 %	
Transverse Sensitivity	≤5 %	
Overload Limit (Shock)	±19600(m/s <sup>2</sup> )pk	±2000gpk
Operating Temp. Range	-55 to +250°C	-67 to +482°F
Polarity ↑	Positive	
Capacitance	850 pF	
Insulation Resistance	>1X10 <sup>11</sup> Ω	
Size (including connector)	18(A/F)x31 mm	0.7”(A/F)x1.22”
Weight	36gm	1.27oz
Sensing Geometry	Shear	
Sensing Element Material	PZT-5	
Case Material	Stainless steel	
Connector Position	Top	
Case sealing	Welded	
Electrical Connection Type	10-32UNF Microdot	
Mounting Thread (tapped base)	10-32UNF	
Mounting Torque	3Nm	26in/lb

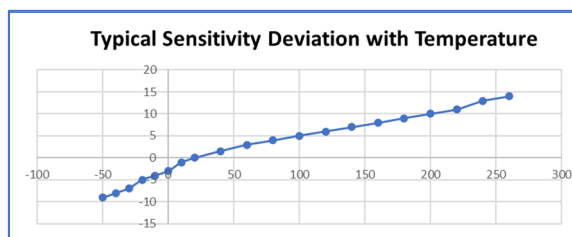
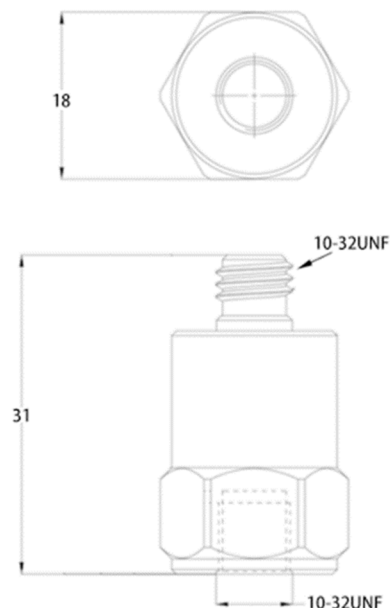

It is recommended that the HGC50T-T is used with a low noise cable from Kemo's range to reduce triboelectric noise.

- 1A2-30 – 3m(10ft) 10/32UNF microdot to BNC plug
- 1A2-50 – 5m(15ft) 10/32UNF microdot to BNC plug
- 1A1-30 – 3m(10ft) 10/32UNFmdot to 10/32UNFmdot
- 1A1-50 – 5m(15ft) 10/32UNFmdot to 10/32UNFmdot

- General Purpose Piezoelectric Accelerometer
- Shear design
- Piezoelectric ceramic PZT-5
- Sensitivity – 10pC/g
- Mass – 6.5grams
- 10-32UNF top entry connector
- Use with a Low noise cable

The HGC10T-T is a high temperature general purpose monoaxial piezoelectric accelerometer with a top entry 10/32UNF microdot connector.

The base of the accelerometer has a tapped hole with a 10/32UNF thread for compatibility with many industry applications.

Featuring a shear design PZT-5 sensing element the HGC10T-T provides high accuracy up to 9kHz. Supplied with a standard 10/32UNF mounting stud (other studs are available on request).

Specification	Metric	Imperial
Sensitivity	1.02pC/(m/s <sup>2</sup> )	10pC/g
Measurement Range (pk)	±9800m/s <sup>2</sup>	±1000g
Frequency Range ±10%	9000 Hz	
Resonant Frequency	≥32 kHz	
Non-Linearity	≤1 %	
Transverse Sensitivity	≤5 %	
Overload Limit (Shock)	±24500(m/s <sup>2</sup> )pk	±2500gpk
Operating Temp. Range	-55 to +250°C	-67 to +482°F
Polarity ↑	Positive	
Capacitance	850 pF	
Insulation Resistance	>1X10 <sup>11</sup> Ω	
Size (including connector)	11(A/F)x21 mm	0.43"(A/F)x0.86"
Weight	6.5gm	0.22oz
Sensing Geometry	Shear	
Sensing Element Material	PZT-5	
Case Material	Titanium	
Connector Position	Top	
Case sealing	Welded	
Electrical Connection Type	10-32UNF Microdot	
Mounting Thread (tapped base)	10-32UNF	
Mounting Torque	3Nm	26in/lb

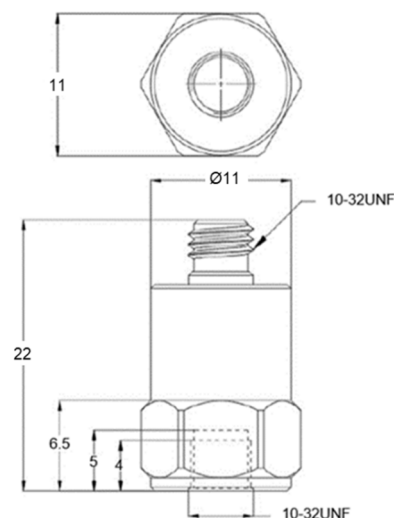

Typical Sensitivity Deviation with Temperature

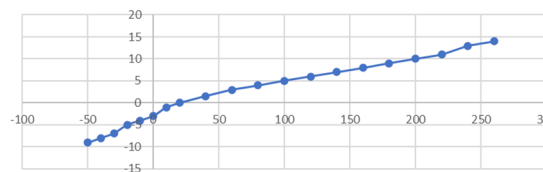

It is recommended that the HGC10T-T is used with a low noise cable from Kemo's range to reduce triboelectric noise.

- 1A2-30 – 3m(10ft) 10/32UNF microdot to BNC plug
- 1A2-50 – 5m(15ft) 10/32UNF microdot to BNC plug
- 1A1-30 – 3m(10ft) 10/32UNFmdot to 10/32UNFmdot
- 1A1-50 – 5m(15ft) 10/32UNFmdot to 10/32UNFmdot

- General Purpose Piezoelectric Accelerometer
- Shear design
- Piezoelectric ceramic PZT-5
- Sensitivity – 10pC/g
- Mass – 6.5grams
- 10-32UNF side entry connector
- Use with a Low noise cable

The HGC10S-T is a high temperature general purpose monoaxial piezoelectric accelerometer with a side entry 10/32UNF microdot connector.

The base of the accelerometer has a tapped hole with a 10/32UNF thread for compatibility with many industry applications.

Featuring a shear design PZT-5 sensing element the HGC10S-T provides high accuracy up to 9kHz. Supplied with a standard 10/32UNF mounting stud (other studs are available on request).

Specification	Metric	Imperial
Sensitivity	1.02pC/(m/s <sup>2</sup> )	10pC/g
Measurement Range (pk)	±9800m/s <sup>2</sup>	±1000g
Frequency Range ±10%	9000 Hz	
Resonant Frequency	≥32 kHz	
Non-Linearity	≤1 %	
Transverse Sensitivity	≤5 %	
Overload Limit (Shock)	±24500(m/s <sup>2</sup> )pk	±2500gpk
Operating Temp. Range	-55 to +250°C	-67 to +482°F
Polarity ↑	Positive	
Capacitance	850 pF	
Insulation Resistance	>1X10 <sup>11</sup> Ω	
Size (excluding connector)	11(A/F)x16 mm	0.43"(A/F)x0.62"
Weight	6.5gm	0.22oz
Sensing Geometry	Shear	
Sensing Element Material	PZT-5	
Case Material	Titanium	
Connector Position	Side	
Case sealing	Welded	
Electrical Connection Type	10-32UNF Microdot	
Mounting Thread (tapped base)	10-32UNF	
Mounting Torque	3Nm	26in/lb

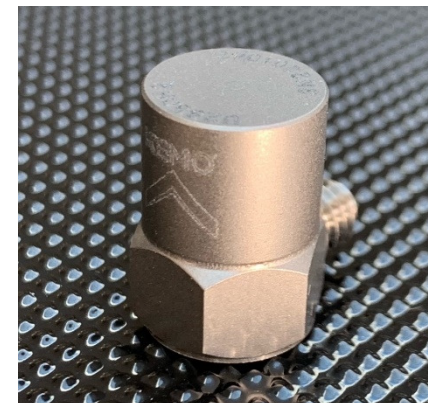
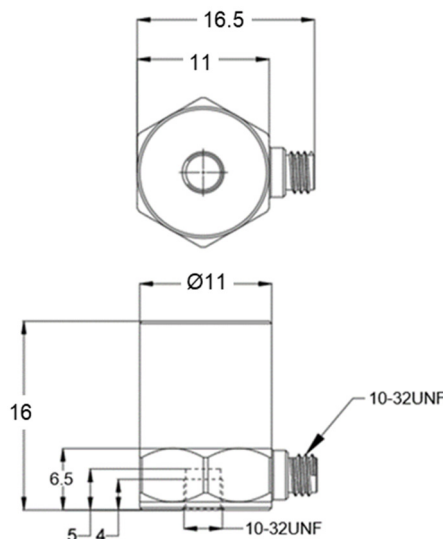

Typical Sensitivity Deviation with Temperature

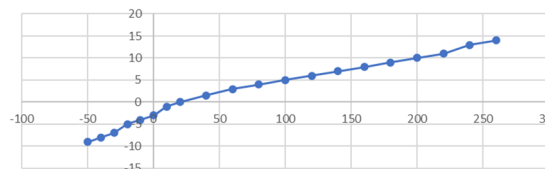

It is recommended that the HGC10S-T is used with a low noise cable from Kemo's range to reduce triboelectric noise.

- 1A2-30 – 3m(10ft) 10/32UNF microdot to BNC plug
- 1A2-50 – 5m(15ft) 10/32UNF microdot to BNC plug
- 1A1-30 – 3m(10ft) 10/32UNFmdot to 10/32UNFmdot
- 1A1-50 – 5m(15ft) 10/32UNFmdot to 10/32UNFmdot

- General Purpose Piezoelectric Accelerometer
- Shear design
- Piezoelectric ceramic PZT-5
- Sensitivity – 30pC/g
- Mass – 12.5grams
- 10-32UNF side entry connector
- Use with a Low noise cable

The HGC30S-T is a high temperature general purpose monoaxial piezoelectric accelerometer with a side entry 10/32UNF microdot connector.

The base of the accelerometer has a tapped hole with a 10/32UNF thread for compatibility with many industry applications.

Featuring a shear design PZT-5 sensing element the HGC30S-T provides high accuracy up to 9kHz. Supplied with a standard 10/32UNF mounting stud (other studs are available on request).

Specification	Metric	Imperial
Sensitivity	3.06pC/(m/s <sup>2</sup> )	30pC/g
Measurement Range (pk)	±9800m/s <sup>2</sup>	±1000g
Frequency Range ±10%	9000 Hz	
Resonant Frequency	≥27 kHz	
Non-Linearity	≤1 %	
Transverse Sensitivity	≤5 %	
Overload Limit (Shock)	±24500(m/s <sup>2</sup> )pk	±2500gpk
Operating Temp. Range	-55 to +250°C	-67 to +482°F
Polarity ↑	Positive	
Capacitance	850 pF	
Insulation Resistance	>1X10 <sup>11</sup> Ω	
Size (excluding connector)	14(A/F)x18 mm	0.55"(A/F)x0.71"
Weight	12.5gm	0.44oz
Sensing Geometry	Shear	
Sensing Element Material	PZT-5	
Case Material	Titanium	
Connector Position	Side	
Case sealing	Welded	
Electrical Connection Type	10-32UNF Microdot	
Mounting Thread (tapped base)	10-32UNF	
Mounting Torque	3Nm	26in/lb

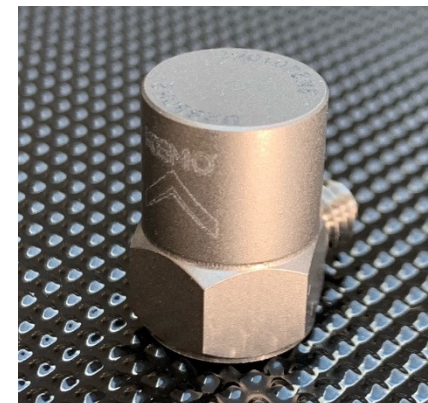
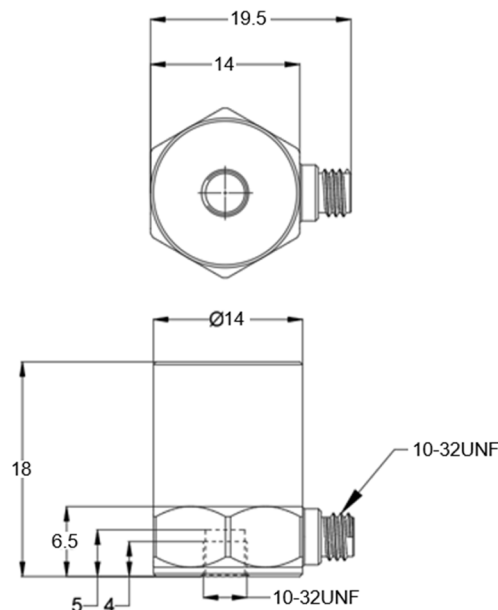

Typical Sensitivity Deviation with Temperature

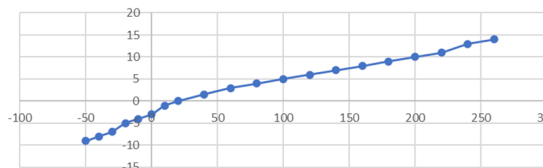

It is recommended that the HGC30S-T is used with a low noise cable from Kemo's range to reduce triboelectric noise.

- 1A2-30 – 3m(10ft) 10/32UNF microdot to BNC plug
- 1A2-50 – 5m(15ft) 10/32UNF microdot to BNC plug
- 1A1-30 – 3m(10ft) 10/32UNFmdot to 10/32UNFmdot
- 1A1-50 – 5m(15ft) 10/32UNFmdot to 10/32UNFmdot