

The Izze-Racing tire temperature sensor is specifically designed to measure the highly transient surface temperature of a tire with spatial fidelity, providing invaluable information for chassis tuning, tire exploitation, compound selection, and driver development.

The sensor is capable of measuring temperature at 16, 8, or 4 laterally-spaced points, at a sampling frequency of up to 100Hz, object temperature between -20 to 300°C, using CAN 2.0A protocol, and enclosed in a compact IP66 rated aluminum enclosure.



The sensor is available with two field-of-views: ultra-wide (120°) or wide (60°).

SENSOR SPECIFICATIONS

Temperature Measurement Range, T_o	-20 to 300°C
Package Temperature Range, T_p	-20 to 85°C
Accuracy (Central 10 Channels, Nominal) (16-Ch Sensor)	$\pm 1.0^\circ\text{C}$ $T_{\text{sensor}} < 50^\circ\text{C}$ $\pm 2.0^\circ\text{C}$ $T_{\text{sensor}} > 50^\circ\text{C}$
Accuracy (First & Last 3 Channels, Nominal) (16-Ch Sensor)	$\pm 2.0^\circ\text{C}$ $T_{\text{sensor}} < 50^\circ\text{C}$ $\pm 3.0^\circ\text{C}$ $T_{\text{sensor}} > 50^\circ\text{C}$
Noise Equivalent Temperature Difference, NETD	0.5°C 16Hz, $\epsilon = 0.85$, $T_o = 25^\circ\text{C}$
Field of View, FOV	60° x 8° (IRTS-60-V2) 120° x 14° (IRTS-120-V2)
Number of Channels	16, 8, or 4
Sampling Frequency	100, 64, 32, 16, 8, 4, 2, or 1Hz
Thermal Time Constant	2 ms
Effective Emissivity	0.01 to 1.00 (default = 0.85)
Spectral Range	8 to 14 μm

ELECTRICAL SPECIFICATIONS

Supply Voltage, V_s	5 to 8 V
Supply Current, I_s (typ)	30 mA
Features	<ul style="list-style-type: none"> Reverse polarity protection Over-temperature protection (125°C)

MECHANICAL SPECIFICATIONS

Weight	< 16.0 g
L x W x H (max, 60° FOV)	37.6 x 26.0 x 12.3 mm
L x W x H (max, 120° FOV)	32 x 29.0 x 12.3 mm
Protection Rating	IP66



Infrared Tire Temperature Sensor, IRTS-V3 - Datasheet

CAN SPECIFICATIONS

Standard	CAN 2.0A (11-bit identifier), ISO-11898
Bit Rate (Default)	1 Mbit/s (configurable)
Byte Order	Big-Endian / Motorola
Data Conversion	0.1°C per bit, -100°C offset, unsigned
Base CAN ID's (Default)	LF Sensor: 1200 (Dec) / 0x4B0 (Hex) RF Sensor: 1204 (Dec) / 0x4B4 (Hex) LR Sensor: 1208 (Dec) / 0x4B8 (Hex) RR Sensor: 1212 (Dec) / 0x4BC (Hex)
Termination	None

CAN ID: Base ID

Infrared Temp, CH 1		Infrared Temp, CH 2		Infrared Temp, CH 3		Infrared Temp, CH 4	
Byte 0 (MSB)	Byte 1 (LSB)	Byte 2 (MSB)	Byte 3 (LSB)	Byte 4 (MSB)	Byte 5 (LSB)	Byte 6 (MSB)	Byte 7 (LSB)

CAN ID: Base ID+1

Infrared Temp, CH 5		Infrared Temp, CH 6		Infrared Temp, CH 7		Infrared Temp, CH 8	
Byte 0 (MSB)	Byte 1 (LSB)	Byte 2 (MSB)	Byte 3 (LSB)	Byte 4 (MSB)	Byte 5 (LSB)	Byte 6 (MSB)	Byte 7 (LSB)

CAN ID: Base ID+2

Infrared Temp, CH 9		Infrared Temp, CH 10		Infrared Temp, CH 11		Infrared Temp, CH 12	
Byte 0 (MSB)	Byte 1 (LSB)	Byte 2 (MSB)	Byte 3 (LSB)	Byte 4 (MSB)	Byte 5 (LSB)	Byte 6 (MSB)	Byte 7 (LSB)

CAN ID: Base ID+3

Infrared Temp, CH 13		Infrared Temp, CH 14		Infrared Temp, CH 15		Infrared Temp, CH 16	
Byte 0 (MSB)	Byte 1 (LSB)	Byte 2 (MSB)	Byte 3 (LSB)	Byte 4 (MSB)	Byte 5 (LSB)	Byte 6 (MSB)	Byte 7 (LSB)

WIRING SPECIFICATIONS:

Wire	26 AWG M22759/32, DR25 jacket
Cable Length (typ.)	500 mm
Connector	None

Supply Voltage, V _s	Red
Ground	Black
CAN +	Blue
CAN -	White

SENSOR CONFIGURATION:

To modify the sensor's configuration, send the following CAN message at 1Hz for at least 10 seconds and then reset the sensor by cycling power:

CAN ID: Current Base ID

Programming Constant		New CAN Base ID (11-bit)		Emissivity	Sampling Frequency	Channels	Bite Rate
Byte 0 (MSB)	Byte 1 (LSB)	Byte 2 (MSB)	Byte 3 (LSB)	Byte 4	Byte 5	Byte 6	Byte 7
30000 = 0x7530		1 = 0x001		1 = 0.01	1 = 1Hz 5 = 16Hz	40 = 4 Ch	1 = 1 Mbit/s
		⋮		⋮	2 = 2Hz 6 = 32Hz	80 = 8 Ch	2 = 500 kbit/s
		2047 = 0x7FF		100 = 1.00	3 = 4Hz 7 = 64Hz	160 = 16 Ch	3 = 250 kbit/s
					4 = 8Hz *8 = 100Hz		4 = 100 kbit/s

* ONLY IRTS-60-V3 (60° FOV)

CAN messages should only be sent to the sensor during the configuration sequence.
DO NOT continuously send CAN messages with the same Base CAN ID to the sensor.

DIMENSIONS:

60° Field-of-View, IRTS-60-V3

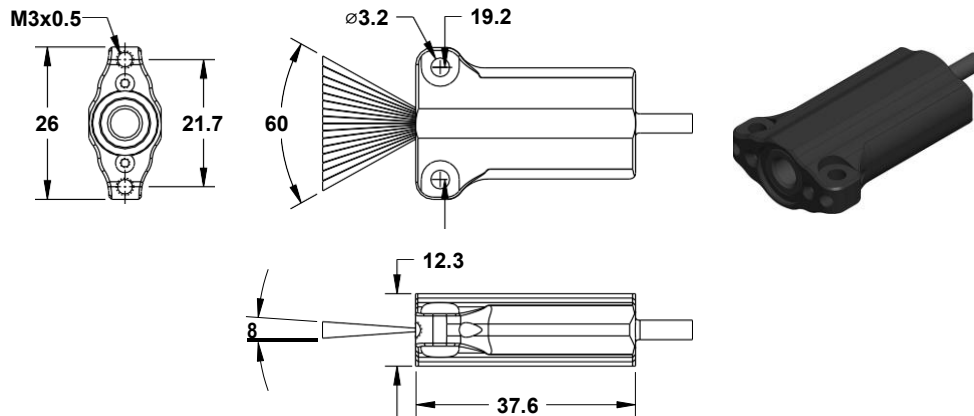

120° Field-of-View, IRTS-120-V3

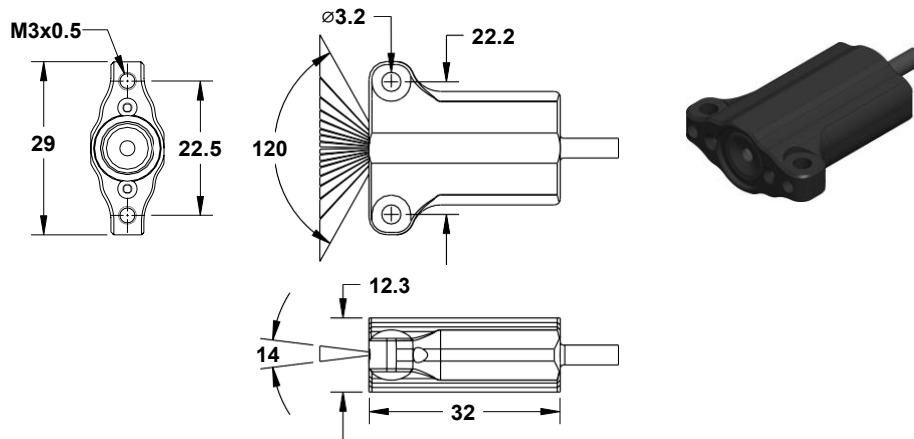



60° Field-of-View, IRTS-60-V3:

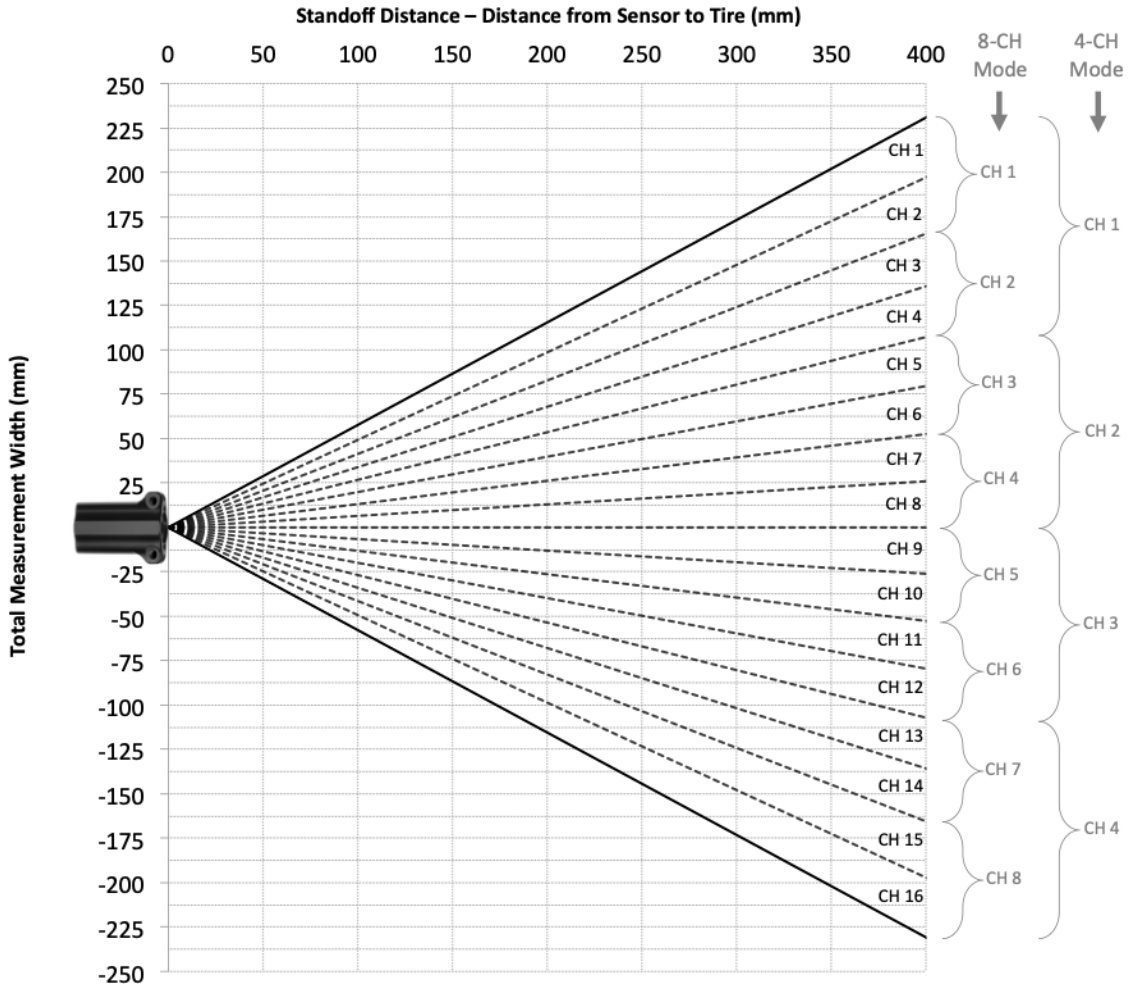

(Angle offset, z-axis rotation, between -5° and +5°, mounts should allow adjustment accordingly)

120° Field-of-View, IRTS-120-V3:

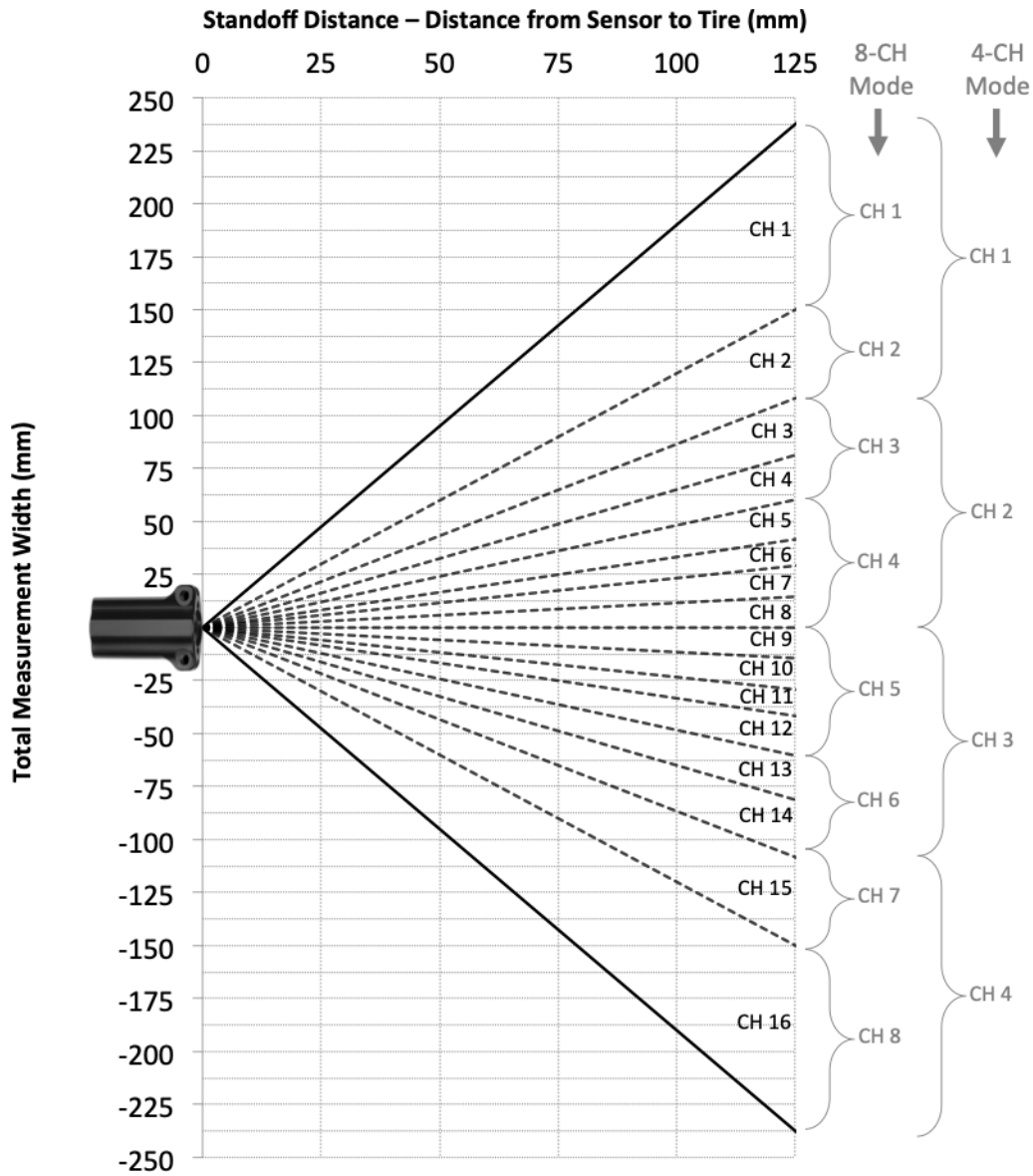

(Angle offset, z-axis rotation, between -5° and +5°, mounts should allow adjustment accordingly)

FRONT FACE MOUNTING, IRTS-120-V3:

- With the IRTS-120-V3, care has to be taken when mounting from the front face holes given the wide width (120°) of the infrared temperature channels. If the mounting bolt standoff from the front face is greater than 3mm, then it will partially block temperature channels 1 and 16.
- It's recommended to use M3 x 0.5 flat head bolts with a 90° countersunk hole to keep bolt-to-face standoff distances < 3mm.
- If this cannot be prevented, ignore temperature readings from CH1 and CH16.

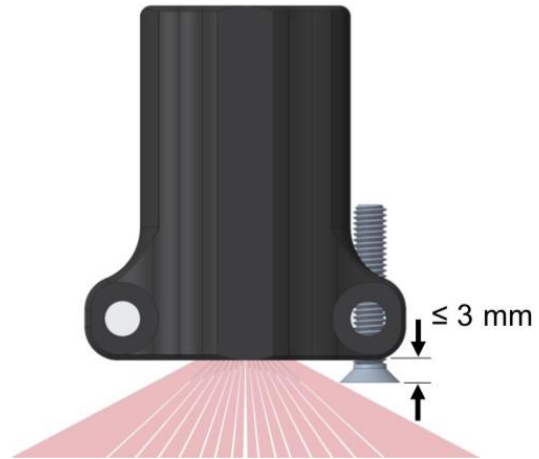

GERMANIUM PROTECTIVE WINDOW, IRTS-GE-V1:

- A Germanium protective window is available for applications subjected to impinging debris (e.g., sensor placed behind tire).
- The window is specifically designed for the IRTS sensor to achieve superior accuracy with minimal IR signal attenuation.
 - i** The effective emissivity is lowered by ~10% with the window installed
 - Default emissivity, window installed = 0.75 (IRTS-120-V3), 0.66 (IRTS-60-V3)
- The window mounts with two #00 Philips screws.
 - i** Screws require blue thread locker
 - !** Use as little torque as possible; too much torque will preload window and increase likelihood of shattering. Torque screws to no more than 0.02 N-m (0.17 lb-in).



ADDITIONAL INFORMATION:

- Stated accuracy is under isothermal package conditions; for utmost accuracy, avoid abrupt temperature transients and gradients across the sensor's package.
- Point the sensor in the downstream direction (facing front of tire) to avoid contamination, pitting, and/or destruction of the sensor's lens from debris. Germanium protective windows are available as an optional extra for protection and upstream facing applications.
- The *effective* emissivity of most tires ranges from approximately 0.75 to 0.90 in the 8 to 14 μm spectrum.
 - o Generally, the emissivity should be lowered as the standoff distance (distance from tire to sensor) increases; this is particularly important with the 60° FOV sensor due to the larger standoff distances required. The suggested emissivity vs. standoff distance is shown in the graph below:

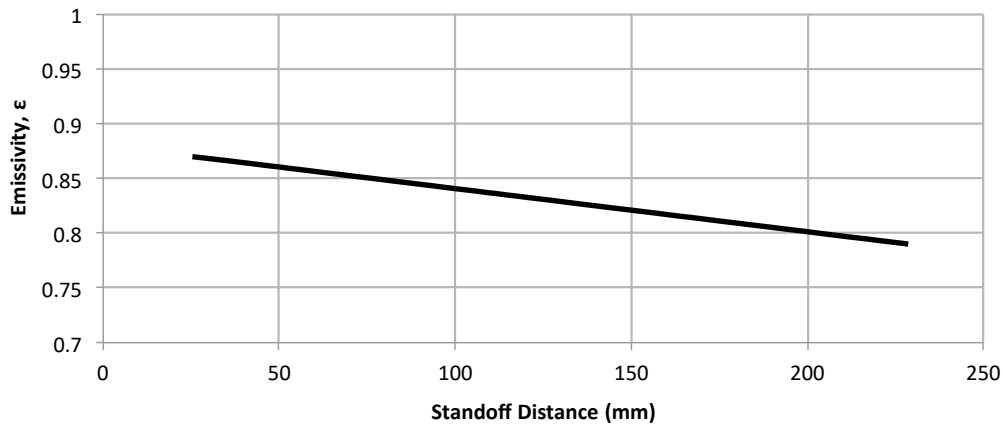

- o Lowering the emissivity increases the measured object temperature and vice versa
- Noise Equivalent Temperature Difference (NETD) increases with increasing sampling frequency:
 - o Provided that tire surface temperature is highly transient, it is usually advantageous to use a higher sampling frequency at the cost of increased noise. A sampling frequency of 32 Hz is recommended for most applications.

