

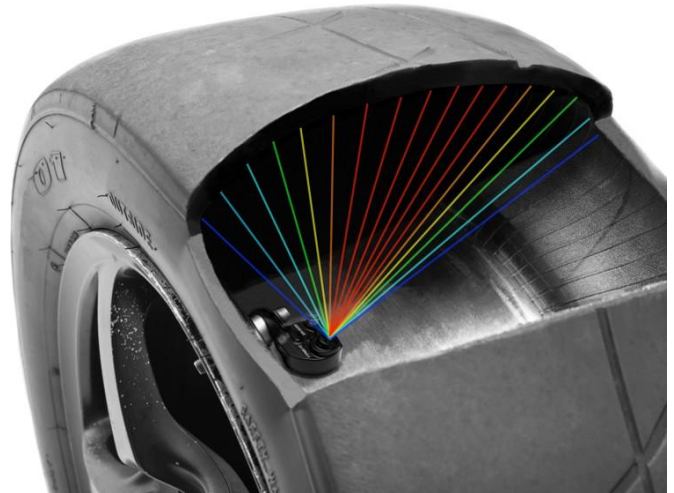

## Tire Temperature and Pressure Monitoring System - Datasheet

The Izze-Racing wireless Tire Temperature and Pressure Monitoring System (TTPMS) consists of small, lightweight, wheel-mounted sensors and an equally small receiver with a built in pressure transducer for high-accuracy gauge pressure measurements. The wireless sensor accurately measures the lateral temperature distribution of the inner tire carcass with an ultra-wide 16-channel infrared sensor and pressure with a high-resolution 24-bit pressure transducer, providing invaluable tire data for motorsport and R&D applications.



### SPECIFICATIONS – TTPMS SENSOR

Pressure, Range (Absolute)	0 to 5000 mBar
Pressure, Resolution	1 mBar
Pressure, FS Accuracy (typ)	±5 mBar
Internal Temperature, Range	-40 to 150°C
Internal Temperature, Resolution	0.1°C
Internal Temperature, FS Accuracy	±0.25°C
IR Temperature, Range	-20 to 300°C
IR Temperature, Resolution	0.1°C
IR Temperature, Accuracy (typ)	±0.5°C
Sampling Period at Speed	1.25 seconds
Operating Temperature Range*	0 to 135°C
Battery Life (typ)	1.5 million transmissions
Encryption	AES-128
RF Frequency	868, 915, 920 MHz
RF Output Power	1mW
Wireless Range, Open Space	> 100m

\*Will survive brief temperature excursions < 150°C

### MECHANICAL SPECS – SENSOR

Weight	21 ± 1g
	7075-T6
	2000G (SF = 3)
	44 x 32 x 18 mm
Protection Rating	IP61

### SPECIFICATIONS – RECEIVER

Voltage Input	5 to 16 V
Supply Current	30 mA
Temperature Range	-20 to 85°C
Max No. of Sensors	120 (30 / corner)
RF Center Frequency	868, 915, 920 MHz
Sensitivity (typ)	-110dBm



### MECHANICAL SPECS – RECEIVER

Weight	18 ± 1g
Material	6061-T6
L x W x H (max)	50.5 x 35.5 x 8 mm
Protection Rating	IP65



# Tire Temperature and Pressure Monitoring System - Datasheet

## INFRARED TEMPERATURE ACCURACY:

- A proprietary calibration (W-REC-V2 S/N > 00685) accounts for multiple variables (infrared radiation, wheel temperature, pressure, sensor temperature, spatial distribution, etc.) to achieve class-leading temperature accuracy for internal tire carcass temperature measurement:

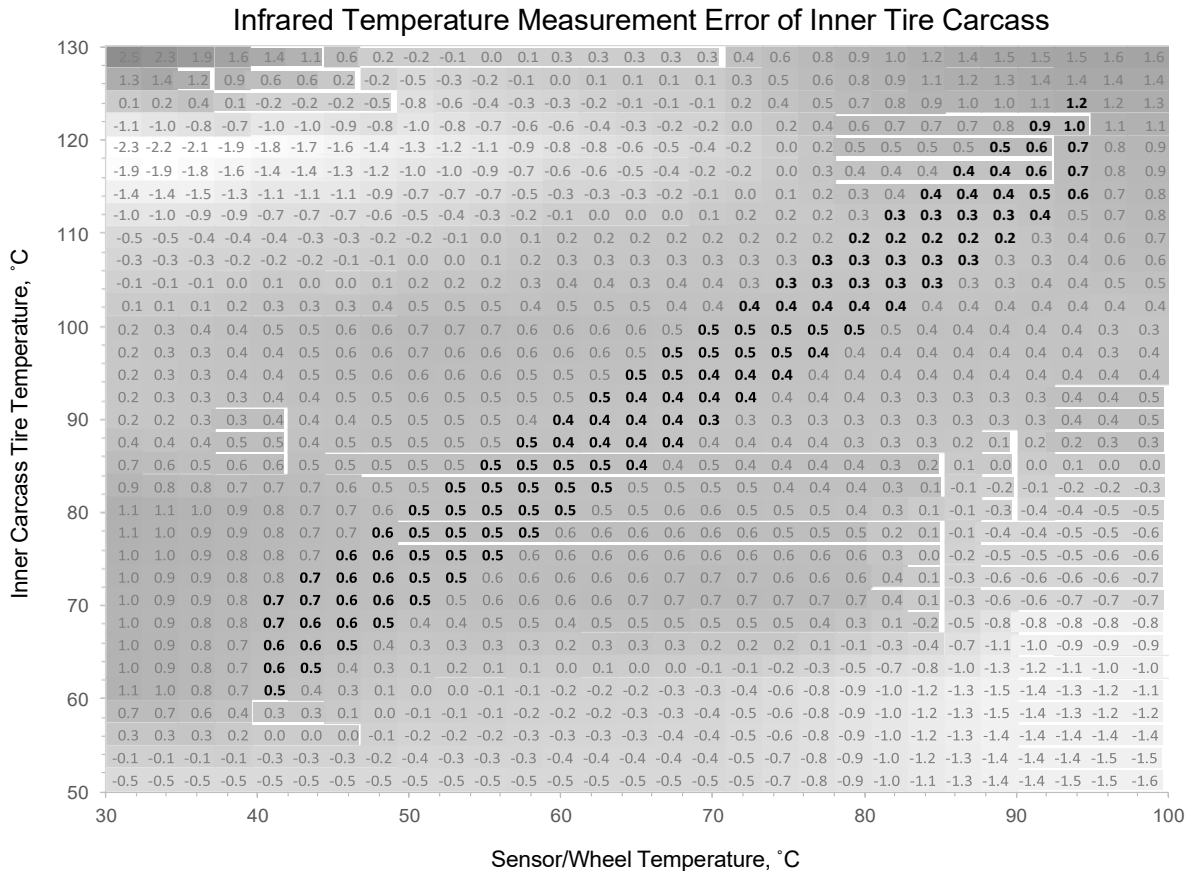

Test Conditions: 1.0 – 3.5 bar, air, 20-50% humidity, infrared channels 5 to 12

\* Bold = Typical operating region

	IR CH 1–4 (inside)	IR CH 5–12 (central)	IR CH 13–16 (outside)
<b>Average Error</b>	+0.9°C	+0.5°C	+0.5°C



# Tire Temperature and Pressure Monitoring System - Datasheet

## CAN SPECIFICATIONS – RECEIVER

Standard	CAN 2.0A, ISO-11898	
Bit Rate	1 Mbit/s (configurable)	
Byte Order	Big-Endian / Motorola	
Data Conversion	1 integer per bit	SN, TC, Node ID
	1 dBm per bit	RSSI
	1mV per bit	Battery Voltage
	1 mBar per bit	Pressure
	0.1°C per bit, -100°C offset (all variables unsigned except RSSI)	Temperature
Base CAN ID (default)	1030 (Dec) / 0x406 (Hex)	
Termination	None	

## WIRING SPECS – RECEIVER:

Wire	M22759/32-26, DR25
Cable Length	500 mm
Connector	None
Supply Voltage, V <sub>s</sub>	Red
Ground	Black
CAN +	Blue
CAN -	White

## CAN MESSAGE STRUCTURE – RECEIVER:

CAN ID: 0x406 (LF) / 0x40C (RF) / 0x412 (LR) / 0x418 (RR)

Serial Number		Battery Voltage		Pressure		Gauge Pressure	
Byte 0 (MSB)	Byte 1 (LSB)	Byte 2 (MSB)	Byte 3 (LSB)	Byte 4 (MSB)	Byte 5 (LSB)	Byte 6 (MSB)	Byte 7 (LSB)

CAN ID: 0x407 (LF) / 0x40D (RF) / 0x413 (LR) / 0x419 (RR)

Infrared Temp, CH 1		Infrared Temp, CH 2		Infrared Temp, CH 3		Infrared Temp, CH 4	
Byte 0 (MSB)	Byte 1 (LSB)	Byte 2 (MSB)	Byte 3 (LSB)	Byte 4 (MSB)	Byte 5 (LSB)	Byte 6 (MSB)	Byte 7 (LSB)

CAN ID: 0x408 (LF) / 0x40E (RF) / 0x414 (LR) / 0x41A (RR)

Infrared Temp, CH 5		Infrared Temp, CH 6		Infrared Temp, CH 7		Infrared Temp, CH 8	
Byte 0 (MSB)	Byte 1 (LSB)	Byte 2 (MSB)	Byte 3 (LSB)	Byte 4 (MSB)	Byte 5 (LSB)	Byte 6 (MSB)	Byte 7 (LSB)

CAN ID: 0x409 (LF) / 0x40F (RF) / 0x415 (LR) / 0x41B (RR)

Infrared Temp, CH 9		Infrared Temp, CH 10		Infrared Temp, CH 11		Infrared Temp, CH 12	
Byte 0 (MSB)	Byte 1 (LSB)	Byte 2 (MSB)	Byte 3 (LSB)	Byte 4 (MSB)	Byte 5 (LSB)	Byte 6 (MSB)	Byte 7 (LSB)

CAN ID: 0x40A (LF) / 0x410 (RF) / 0x416 (LR) / 0x41C (RR)

Infrared Temp, CH 13		Infrared Temp, CH 14		Infrared Temp, CH 15		Infrared Temp, CH 16	
Byte 0 (MSB)	Byte 1 (LSB)	Byte 2 (MSB)	Byte 3 (LSB)	Byte 4 (MSB)	Byte 5 (LSB)	Byte 6 (MSB)	Byte 7 (LSB)

CAN ID: 0x40B (LF) / 0x411 (RF) / 0x417 (LR) / 0x41D (RR)

Transmission Count		RSSI		Sensor Temperature		Sensor Node ID	
Byte 0 (MSB)	Byte 1 (LSB)	Byte 2 (MSB)	Byte 3 (LSB)	Byte 4 (MSB)	Byte 5 (LSB)	Byte 6 (MSB)	Byte 7 (LSB)

\* The base CAN ID (0x406) is adjustable



**BASE CAN ID PROGRAMMING – RECEIVER:**

To modify the wireless receiver’s base CAN ID, sensor assignment mode, or bit rate, send the following CAN message at 1Hz for at least 10 seconds and then reset the receiver by disconnecting power for 5 seconds. For more details and options, refer to the Appendix.

CAN ID = Base ID (Default = 0x406)

Programming Constant		New CAN Base ID (11-bit)		Sensor Assignment	Bit Rate	Emissivity	
Byte 0 (MSB)	Byte 1 (LSB)	Byte 2 (MSB)	Byte 3 (LSB)	Byte 4	Byte 5	Byte 6	Byte 7
30000 = 0x7530		1 = 0x001 : : 2047 = 0x7FF		1 = Default 2 = Custom	1 = 1 Mbit/s 2 = 500 kbit/s 3 = 250 kbit/s 4 = 125 kbit/s	1 = Default 2 = Custom 0 = Std.	0

CAN messages should only be sent to the receiver during the configuration sequence.

**DO NOT continuously send CAN messages to the receiver.**

**DIMENSIONS:**

**TTPMS Sensor, TTPMS-V2**

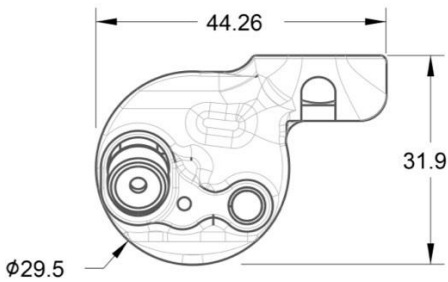

ALL DIMENSIONS IN MM

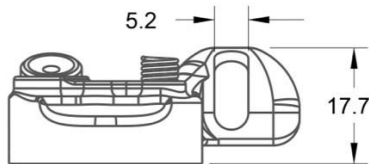

17mm Ball Socket for Valve

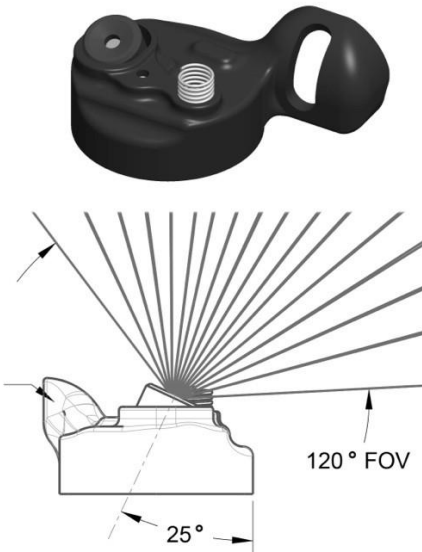

**WHIP ANTENNA VARIANT**

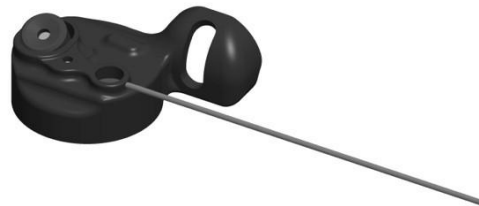
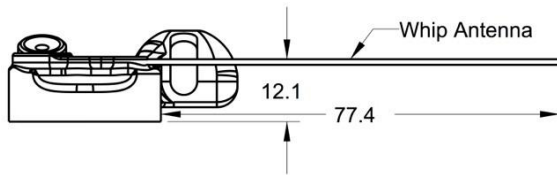

(Antenna chosen based on our discernment; whip increases tire bead clearance and wireless range)

TTPMS Receiver, W-REC-V2

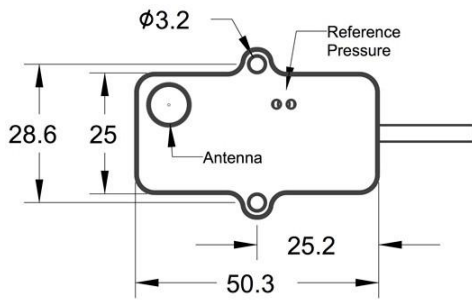

ALL DIMENSIONS IN MM

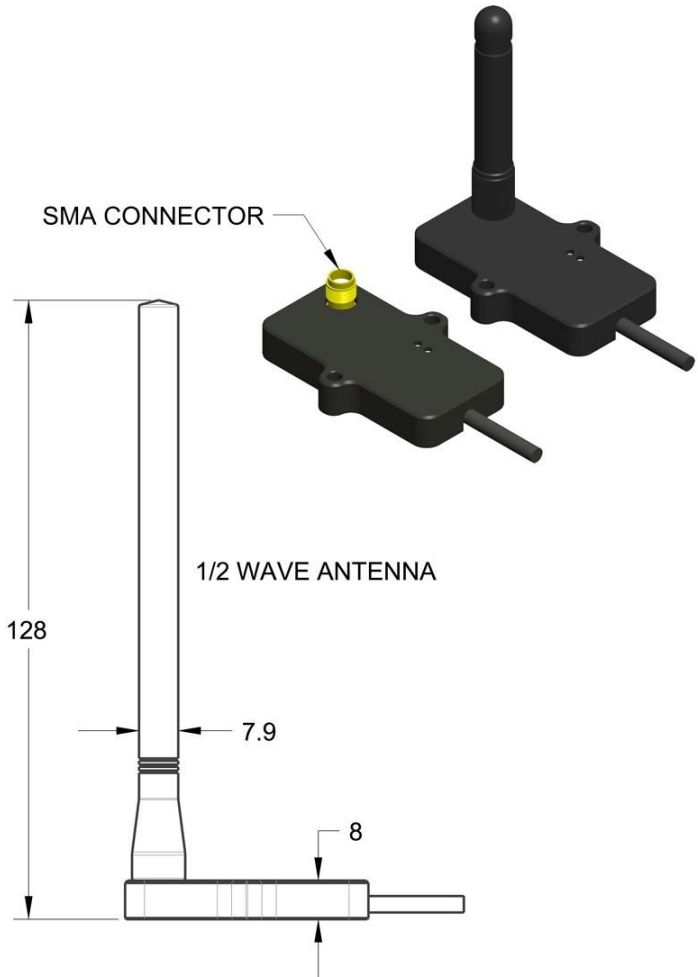
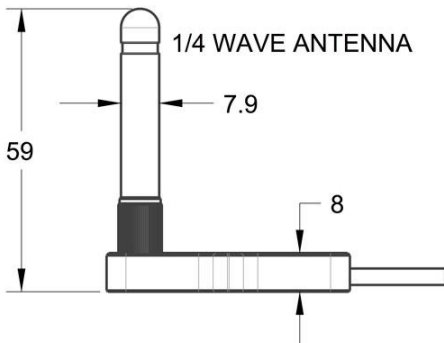



120° Field-of-View, Spatial Mapping of Temperature Channels:

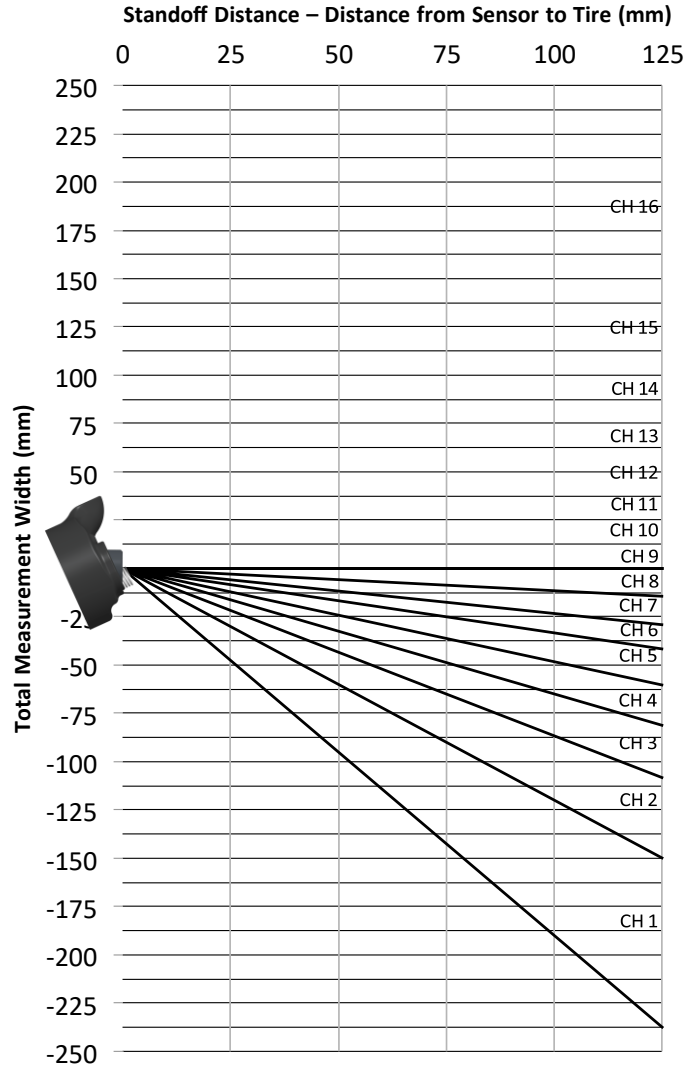

\*CAD model available with temperature channel rays\*

TRANSMISSION RATE:

State	Criteria	Data	Update Period
Uninflated or Cold	$P_{\text{gauge}} < 250\text{mBar}$ $T_{\text{sensor}} < 5^{\circ}\text{C}$	None	N/A (sleeping)
Inflated	$P_{\text{gauge}} > 250\text{mBar}$	Pressure	240 seconds
Inflated & Heated	$P_{\text{gauge}} > 250\text{mBar}$ $T_{\text{sensor}} > 40^{\circ}\text{C}$	Pressure	10 seconds
Inflated & $\Delta P$	$P_{\text{gauge}} > 250\text{mBar}$ $\Delta P_{\text{gauge}} > 10\text{mBar}$	Pressure, Infrared	1.2 seconds*
Rotation	Wheel movement	Pressure, Infrared	1.2 seconds*

\* 10 second overrun before switching to lower state / longer update period

## SYSTEM LAYOUT (DEFAULT):

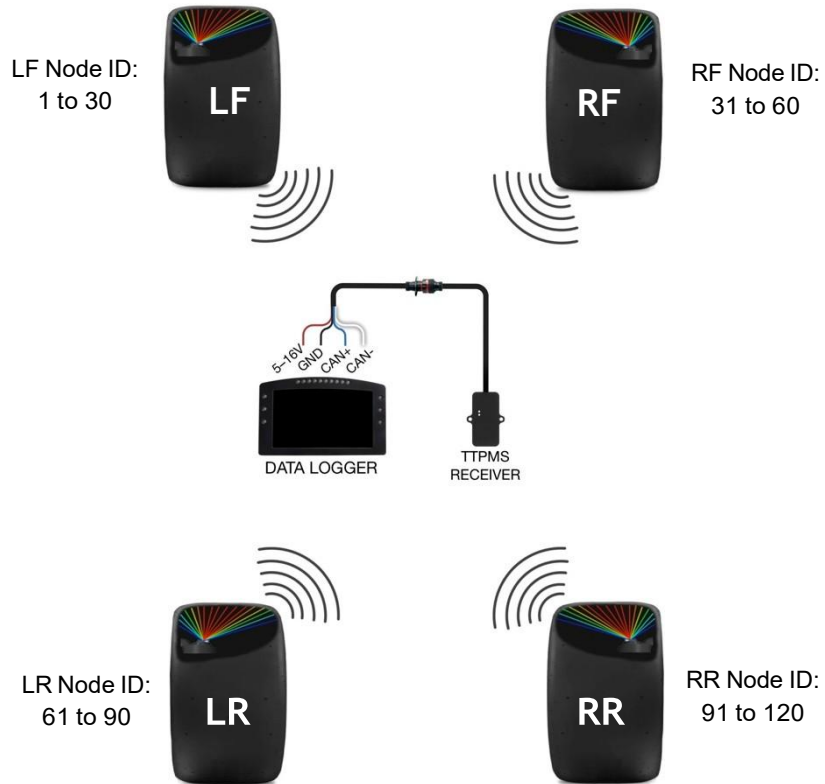

- Place receiver near center of car, in cockpit, with antenna perpendicular to any metal or carbon-fiber surface. Most applications will only require one receiver, but a chassis with difficult RF penetration may require two receivers (front and rear).

## TIRE CORNER ASSIGNMENT – TTPMS SENSOR:

- By default, each TTPMS sensor is assigned to a specific corner/tire with a unique Node ID:

**LF Node ID's:** 1 to 30

**RF Node ID's:** 31 to 60

**LR Node ID's:** 61 to 90

**RR Node ID's:** 91 to 120

- The corner assignment for each Node ID is adjustable; refer to the Appendix for details.
- Each team/set will be assigned a receiver with a unique Network ID and AES-128 encryption, therefore, protecting data between teams and cars.
- The receiver will acquire data from all active TTPMS sensors in the pits but will only receive data from the fitted, active tires when away from the pits.



## ADDITIONAL INFORMATION:

- Battery life depends on a multitude of operating conditions but will typically exceed 1 million transmissions (347 track hours) or up to approximately 3 years.
  - o The TTPMS sensor is fitted with a serviceable battery.
    - Instructions: [izzeracing.com/products/ewExternalFiles/TTPMS\\_V2\\_Battery\\_Replacement.pdf](http://izzeracing.com/products/ewExternalFiles/TTPMS_V2_Battery_Replacement.pdf)
  - o **It is advisable to proactively replace the battery every 18-24 months.**
- The maximum recommended sensor temperature is 120°C for utmost reliability and battery life, but transient temperature excursions up to 150°C are survivable.
- To avoid dropped packets, the average Received Signal Strength Indication (RSSI) should be no less than -90dBm.
  - o Two receivers may be used when signal strength is too weak with one receiver.
- Do not wash the TTPMS sensors – keep dry.
- Do not repeatedly remove and reinstall the sensor & valve assembly.

## PART NUMBERS:

Part No.	Description
TTPMS-V2	TTPMS Sensor
W-REC-V2	TTPMS Receiver
AV-STD-49	TTPMS Sensor Valve



## APPENDIX

### A.1 – BASIC RECEIVER PROGRAMMING:

To modify the wireless receiver’s base CAN ID, sensor assignment mode, bit rate, or emissivity, send the following CAN message at 1Hz for at least 10 seconds and then reset the receiver by disconnecting power for 5 seconds.

CAN ID = Base ID (Default = 0x406)

Programming Constant		New CAN Base ID (11-bit)		Sensor Assignment	Bit Rate	Emissivity	
Byte 0 (MSB)	Byte 1 (LSB)	Byte 2 (MSB)	Byte 3 (LSB)	Byte 4	Byte 5	Byte 6	Byte 7
30000 = 0x7530		1 = 0x001 : 2047 = 0x7FF		1 = Default 2 = Custom	1 = 1 Mbit/s 2 = 500 kbit/s 3 = 250 kbit/s 4 = 100 kbit/s	1 = Default 2 = Custom 0 = Std.	0

CAN messages should only be sent to the receiver during the configuration sequence.

**DO NOT continuously send CAN messages to the receiver.**

## A.2 – ADVANCED EMISSIVITY ADJUSTMENT (OPTIONAL):

Long-wave infrared radiation attenuates with increasing optical distance / standoff distance, increasing pressure, and changes with gas mixtures. The *effective emissivity* for each infrared temperature channel may be adjusted in order to compensate for unusual circumstances.

**Note:** The default infrared temperature calibration automatically compensates for the accuracy dependent variables (infrared radiation, spatial location, pressure, wheel temperature, etc.) and should be used for almost all cases; please contact IZZE-RACING if it's deemed the advanced emissivity adjustment is necessary.

- The *effective emissivity* slightly decreases with increasing optical distance, as quantified in the sample chart below. As shown in the sample model, the first couple infrared temperature channels have much longer optical distances than the other channels; therefore, the *effective emissivity* will be lower for the first couple channels in order to compensate for the longer optical distance.
- The *effective emissivity* decreases with increasing pressure, as shown in the sample chart below for air (low-humidity). The sensitivity to pressure will depend on the gas mixture but is typically significant in one bar increments.
- Example:

Pressure = 2 bar, T1<sub>Optical Length</sub> = 270mm, T12<sub>Optical Length</sub> = 100mm

$$\epsilon_{T1} \approx -0.00039 \times 270\text{mm} + 0.82 \approx 0.71, \quad \epsilon_{T12} \approx -0.00039 \times 100\text{mm} + 0.82 \approx 0.78$$

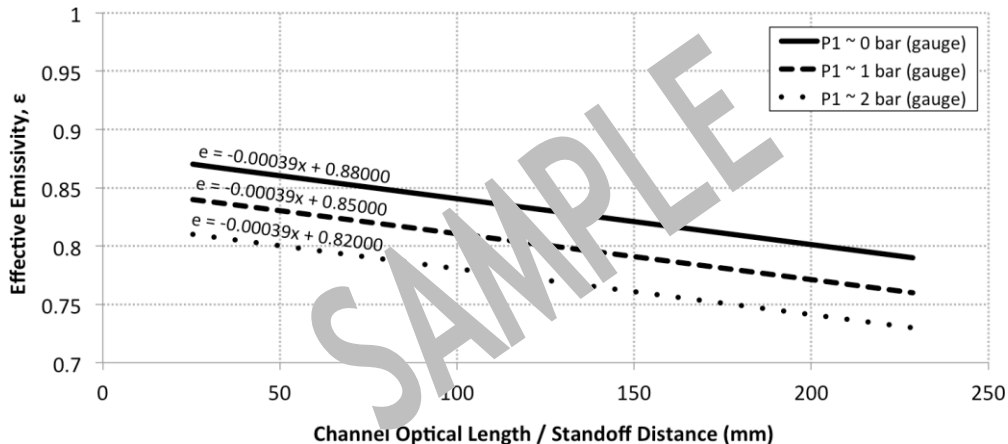
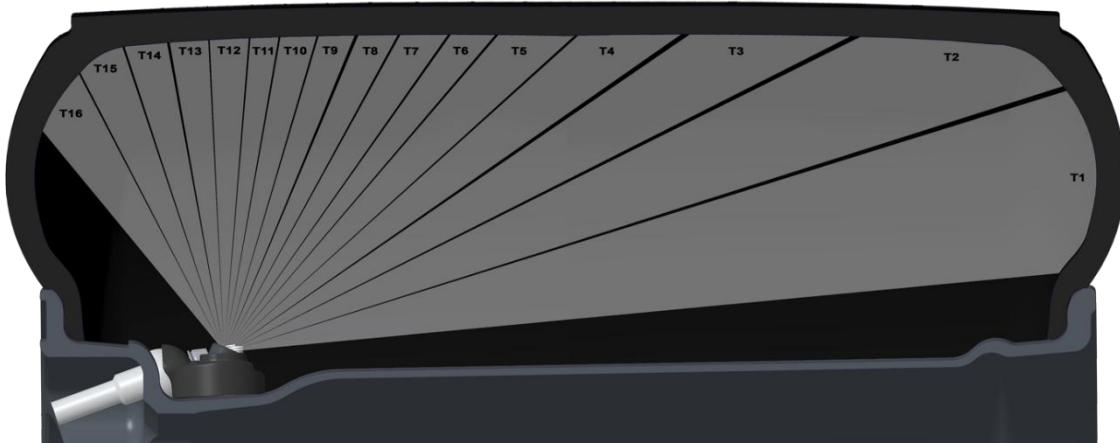

## CAN MESSAGE for PROGRAMMING EMISSIVITY:

- "Emissivity" (Byte 5 in Section A.1) must be set to "Custom" (i.e., Byte 5 = 2) in order to activate custom emissivity assignments.

### CAN ID = Base ID (Default = 0x406)

Programming Constant		$\epsilon$ , T1	$\epsilon$ , T2	$\epsilon$ , T3	$\epsilon$ , T4	$\epsilon$ , T5	$\epsilon$ , T6
Byte 0 (MSB)	Byte 1 (LSB)	Byte 2	Byte 3	Byte 4	Byte 5	Byte 6	Byte 7
20030 = 0x4E3E = LF		.01 = 0x01	.01 = 0x01	.01 = 0x01	.01 = 0x01	.01 = 0x01	.01 = 0x01
20040 = 0x4E48 = RF		⋮	⋮	⋮	⋮	⋮	⋮
20050 = 0x4E52 = LR		1.0 = 0x64	1.0 = 0x64	1.00 = 0x64	1.00 = 0x64	1.00 = 0x64	1.00 = 0x64
20060 = 0x4E5C = RR							

### CAN ID = Base ID (Default = 0x406)

Programming Constant		$\epsilon$ , T7	$\epsilon$ , T8	$\epsilon$ , T9	$\epsilon$ , T10	$\epsilon$ , T11	$\epsilon$ , T12
Byte 0 (MSB)	Byte 1 (LSB)	Byte 2	Byte 3	Byte 4	Byte 5	Byte 6	Byte 7
20031 = 0x4E3F = LF		.01 = 0x01	.01 = 0x01	.01 = 0x01	.01 = 0x01	.01 = 0x01	.01 = 0x01
20041 = 0x4E49 = RF		⋮	⋮	⋮	⋮	⋮	⋮
20051 = 0x4E53 = LR		1.0 = 0x64	1.0 = 0x64	1.00 = 0x64	1.00 = 0x64	1.00 = 0x64	1.00 = 0x64
20061 = 0x4E5D = RR							

### CAN ID = Base ID (Default = 0x406)

Programming Constant		$\epsilon$ , T13	$\epsilon$ , T14	$\epsilon$ , T15	$\epsilon$ , T16	$\epsilon$ , Default	Byte 7
Byte 0 (MSB)	Byte 1 (LSB)	Byte 2	Byte 3	Byte 4	Byte 5	Byte 6	Byte 7
20032 = 0x4E40 = LF		.01 = 0x01	.01 = 0x01	.01 = 0x01	.01 = 0x01	.76 = 0x4C	
20042 = 0x4E4A = RF		⋮	⋮	⋮	⋮		
20052 = 0x4E54 = LR		1.0 = 0x64	1.0 = 0x64	1.00 = 0x64	1.00 = 0x64	DO NOT CHANGE	
20062 = 0x4E5E = RR							



**A.3 – CUSTOM CORNER ASSIGNMENT OF TTPMS SENSOR NODE ID’S:**

- Each sensor is assigned a unique Node ID; the receiver may be programmed to assign any Node ID to any of the four wheels (LF, RF, LR, or RR).
- “Sensor Assignment” (Byte 4 in CAN message above) must be set to “Custom” (i.e., Byte 4 = 2) in order to activate custom corner assignments.

**CAN MESSAGE for PROGRAMMING NODE ID ASSIGNMENTS:**

CAN ID = Base ID (Default = 0x406)

Programming Constant		ID - 1	ID - 2	ID - 3	ID - 4	ID - 5	ID - 6
Byte 0 (MSB)	Byte 1 (LSB)	Byte 2	Byte 3	Byte 4	Byte 5	Byte 6	Byte 7
20000 = 0x4E20 = LF		0 = 0x00	0 = 0x00	0 = 0x00	0 = 0x00	0 = 0x00	0 = 0x00
20002 = 0x4E22 = RF		:	:	:	:	:	:
20004 = 0x4E24 = LR		120 = 0x78	120 = 0x78	120 = 0x78	120 = 0x78	120 = 0x78	120 = 0x78
20006 = 0x4E26 = RR							

CAN ID = Base ID (Default = 0x406)

Programming Constant		ID - 7	ID - 8	ID - 9	ID - 10	ID - 11	ID - 12
Byte 0 (MSB)	Byte 1 (LSB)	Byte 2	Byte 3	Byte 4	Byte 5	Byte 6	Byte 7
20001 = 0x4E21 = LF		0 = 0x00	0 = 0x00	0 = 0x00	0 = 0x00	0 = 0x00	0 = 0x00
20003 = 0x4E23 = RF		:	:	:	:	:	:
20005 = 0x4E25 = LR		120 = 0x78	120 = 0x78	120 = 0x78	120 = 0x78	120 = 0x78	120 = 0x78
20007 = 0x4E27 = RR							



**A.4 – FILTERING SELECTED CORNER TTPMS SENSORS:**

- The receiver may be programmed to only receive data from selected corners (e.g., LF and RF wheel TTPMS sensors).
- When using multiple receivers on the same CAN Bus, they must be programmed individually.

**CAN MESSAGE for PROGRAMMING CORNER ASSIGNMENTS:**

CAN ID = Base ID (Default = 0x406)

Programming Constant		LF Sensors	RF Sensors	LR Sensors	RR Sensors		
Byte 0 (MSB)	Byte 1 (LSB)	Byte 2	Byte 3	Byte 4	Byte 5	Byte 6	Byte 7
20010 = 0x4E2A		1 = Enabled 2 = Disabled	1 = Enabled 2 = Disabled	1 = Enabled 2 = Disabled	1 = Enabled 2 = Disabled	0 = 0x00	0 = 0x00

**A.5 – RECEIVER NETWORK, NODE ID, and RF FREQUENCY:**

- The receiver’s Network, Node ID, and Radio Frequency (from 868 to 920MHz) may be changed in order to communicate with another set of TTPMS sensors.
- Each team is assigned a unique AES-128 encryption key, so sensors may only be used with different receivers *within the same team*.

**CAN MESSAGE for PROGRAMMING NETWORK, NODE ID, and RF FREQUENCY:**

CAN ID = Base ID (Default = 0x406)

Programming Constant		Network ID	Node ID	Radio Frequency			
Byte 0 (MSB)	Byte 1 (LSB)	Byte 2	Byte 3	Byte 4 (MSB)	Byte 5 (LSB)	Byte 6	Byte 7
20020 = 0x4E34		0 = 0x00 ⋮ 255 = 0xFF	0 = 0x00 ⋮ 255 = 0xFF	Decimal Value x 10 <sup>5</sup> Hz  (ex: 9155 = 915,500,000 Hz)		0 = 0x00	0 = 0x00