

- Shock IEPE Accelerometer
- Shear design
- Piezoelectric ceramic PZT-5
- Range ±5000g
- Mass – 6grams
- 10-32UNF top entry connector
- 10-32UNF Tapped base

The VS-5K is the first in a range of IEPE shock measurement accelerometers offering dedicated shock measurement capability. With a ±5000g range the VS-5K combines the flexibility of IEPE (Integrated Electronics Piezoelectric) technology with the reliability of a robust titanium fully welded construction. Kemo can also offer cables and signal conditioning solutions for use with their full range of accelerometers.

Specification	Metric	Imperial
Sensitivity	0.102mV/(m/s <sup>2</sup> )	1mV/g
Measurement Range (pk)	±49000m/s <sup>2</sup>	±5000g
Frequency Range ±10%	1 to 9000 Hz	
Resonant Frequency	≥25 kHz	
Non-Linearity	≤1 %	
Transverse Sensitivity	≤5 %	
Overload Limit (Shock)	±58800(m/s <sup>2</sup> )pk	±7000gpk
Operating Temp. Range	-40 to +85°C	-40 to +185°F
Polarity ↑	Positive	
Compliance Voltage (Supply)	+18 to +28 VDC	
Current range	2 – 10mA	
Output Bias Voltage	11VDC ± 1.5VDC	
Output Impedance	≤100Ω	
Size (excluding connector)	12.7mmA/Fx16 mm	0.50" A/Fx0.63"
Weight	6gm	0.21oz
Sensing Geometry	Shear	
Sensing Element Material	PZT-5	
Case Material	Titanium	
Connector Position	Top	
Case sealing	Hermetic	
Electrical Connection Type	10-32UNF Microdot	
Mounting	10-32UNF Tapped base for stud mount	

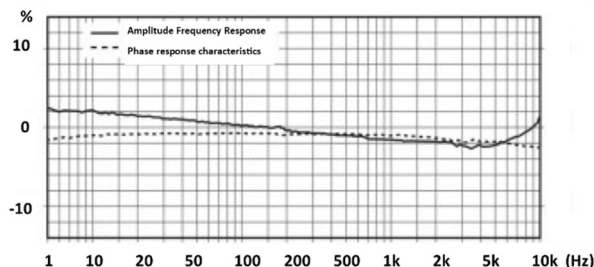
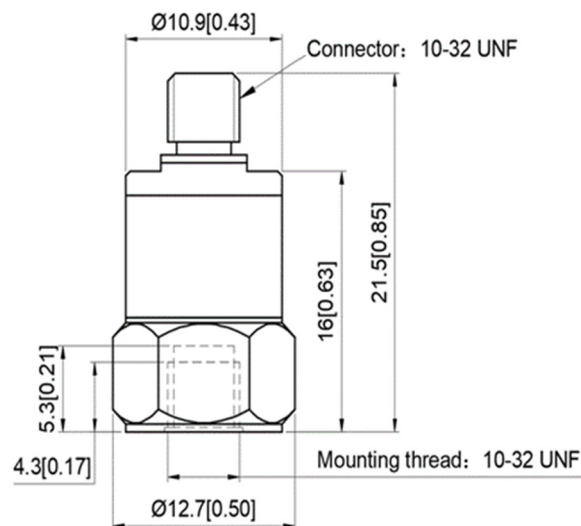

Kemo has a range of cable assemblies available for use with the VS-5K and other IEPE accelerometers.

- 1B2-30 – 3m(10ft) 10/32UNF microdot to BNC plug
- 1B2-50 – 5m(15ft) 10/32UNF microdot to BNC plug
- 1B1-30 – 3m(10ft) 10/32UNFmdot to 10/32UNFmdot
- 1B1-50 – 5m(15ft) 10/32UNFmdot to 10/32UNFmdot

- Shock IEPE Accelerometer
- Shear design
- Piezoelectric ceramic PZT-5
- Range ±10000g
- Mass – 6grams
- 10-32UNF top entry connector
- 10-32UNF Tapped base

The VS-10K is an IEPE shock accelerometer offering dedicated shock measurement capability. With a ±10000g range the VS-10K combines the flexibility of IEPE (Integrated Electronics Piezoelectric) technology with the reliability of a robust titanium fully welded construction.

Kemo can also offer cables and signal conditioning solutions for use with their full range of accelerometers.

Specification	Metric	Imperial
Sensitivity	0.05mV/(m/s <sup>2</sup> )	0.5mV/g
Measurement Range (pk)	±98000m/s <sup>2</sup>	±10000g
Frequency Range ±10%	1 to 9000 Hz	
Resonant Frequency	≥30 kHz	
Non-Linearity	≤1 %	
Transverse Sensitivity	≤5 %	
Overload Limit (Shock)	±117,600(m/s <sup>2</sup> )pk	±12000gpk
Operating Temp. Range	-40 to +85°C	-40 to +185°F
Polarity ↑	Positive	
Compliance Voltage (Supply)	+18 to +28 VDC	
Current range	2 – 10mA	
Output Bias Voltage	11VDC ± 1.5VDC	
Output Impedance	≤100Ω	
Size (excluding connector)	12.7mmA/Fx16 mm	0.50" A/Fx0.63"
Weight	6gm	0.21oz
Sensing Geometry	Shear	
Sensing Element Material	PZT-5	
Case Material	Titanium	
Connector Position	Top	
Case sealing	Hermetic	
Electrical Connection Type	10-32UNF Microdot	
Mounting	10-32UNF Tapped base for stud mount	

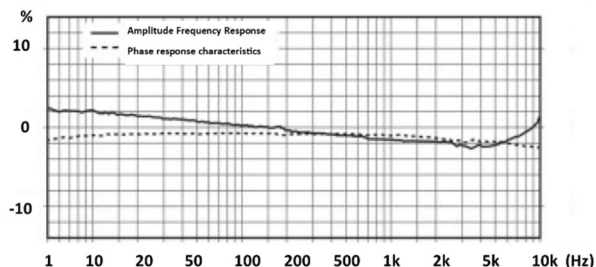
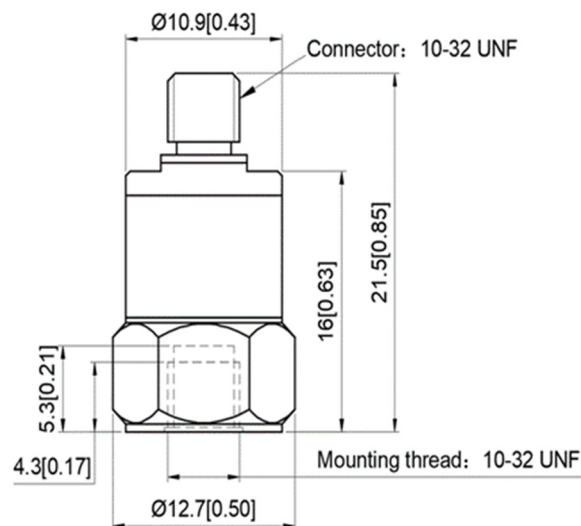

Kemo has a range of cable assemblies available for use with the VS-10K and other IEPE accelerometers.

- 1B2-30 – 3m(10ft) 10/32UNF microdot to BNC plug
- 1B2-50 – 5m(15ft) 10/32UNF microdot to BNC plug
- 1B1-30 – 3m(10ft) 10/32UNFmdot to 10/32UNFmdot
- 1B1-50 – 5m(15ft) 10/32UNFmdot to 10/32UNFmdot

- Shock IEPE Accelerometer
- Shear design
- Piezoelectric ceramic PZT-5
- Range ±10000g
- Mass – 6grams
- 10-32UNF top entry connector
- 10-32UNF Tapped base

The VS-10K is an IEPE shock accelerometer offering dedicated shock measurement capability. With a ±10000g range the VS-10K combines the flexibility of IEPE (Integrated Electronics Piezoelectric) technology with the reliability of a robust titanium fully welded construction.

Kemo can also offer cables and signal conditioning solutions for use with their full range of accelerometers.

Specification	Metric	Imperial
Sensitivity	0.05mV/(m/s <sup>2</sup> )	0.5mV/g
Measurement Range (pk)	±98000m/s <sup>2</sup>	±10000g
Frequency Range ±10%	1 to 9000 Hz	
Resonant Frequency	≥30 kHz	
Non-Linearity	≤1 %	
Transverse Sensitivity	≤5 %	
Overload Limit (Shock)	±117,600(m/s <sup>2</sup> )pk	±12000gpk
Operating Temp. Range	-40 to +85°C	-40 to +185°F
Polarity ↑	Positive	
Compliance Voltage (Supply)	+18 to +28 VDC	
Current range	2 – 10mA	
Output Bias Voltage	11VDC ± 1.5VDC	
Output Impedance	≤100Ω	
Size (excluding connector)	12.7mmA/Fx16 mm	0.50" A/Fx0.63"
Weight	6gm	0.21oz
Sensing Geometry	Shear	
Sensing Element Material	PZT-5	
Case Material	Titanium	
Connector Position	Top	
Case sealing	Hermetic	
Electrical Connection Type	10-32UNF Microdot	
Mounting	10-32UNF Tapped base for stud mount	

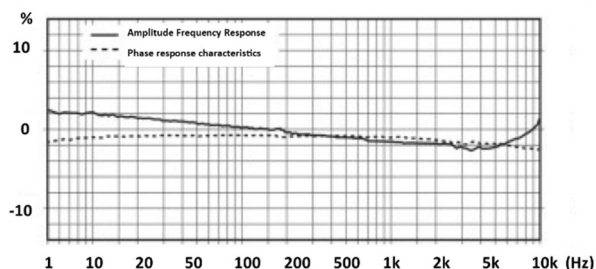
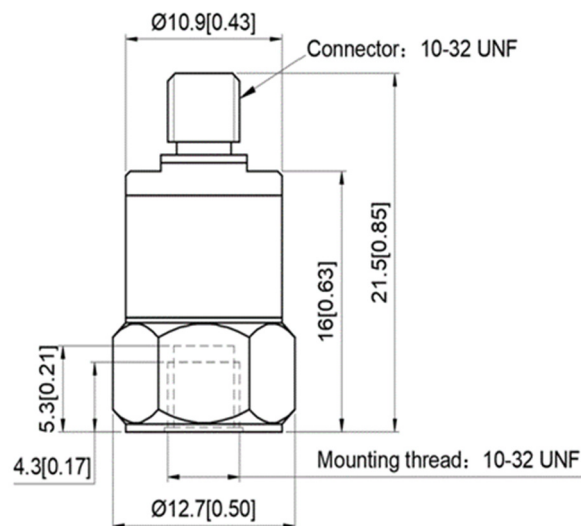

Kemo has a range of cable assemblies available for use with the VS-10K and other IEPE accelerometers.

- 1B2-30 – 3m(10ft) 10/32UNF microdot to BNC plug
- 1B2-50 – 5m(15ft) 10/32UNF microdot to BNC plug
- 1B1-30 – 3m(10ft) 10/32UNFmdot to 10/32UNFmdot
- 1B1-50 – 5m(15ft) 10/32UNFmdot to 10/32UNFmdot

- Shock IEPE Accelerometer
- Shear design
- Piezoelectric ceramic PZT-5
- Range ±50000g
- Mass – 5.5grams
- 0.5m int. cable with 10/32 Mdot plug
- M6 x 0.75 integral stud

The VS-50K is an IEPE shock accelerometer offering dedicated shock measurement capability. With a ±50000g range the VS-50K combines the flexibility of IEPE (Integrated Electronics Piezoelectric) technology with the reliability of a robust titanium fully welded construction.

Kemo can also offer cables and signal conditioning solutions for use with their full range of accelerometers.

Specification	Metric	Imperial
Sensitivity	0.0102mV/(m/s <sup>2</sup> )	0.1mV/g
Measurement Range (pk)	±490000m/s <sup>2</sup>	±50000g
Frequency Range ±10%	1 to 10000 Hz	
Resonant Frequency	≥30 kHz	
Non-Linearity	≤1 %	
Transverse Sensitivity	≤5 %	
Overload Limit (Shock)	±588,000(m/s <sup>2</sup> )pk	±60000gpk
Operating Temp. Range	-40 to +85°C	-40 to +185°F
Polarity ↑	Positive	
Isolation	Case isolated	
Compliance Voltage (Supply)	+18 to +28 VDC	
Current range	2 – 10mA	
Output Bias Voltage	11VDC ± 1.5VDC	
Output Impedance	≤100Ω	
Size (excluding connector)	10.8mmA/Fx16.7 mm	0.43”A/Fx0.66”
Weight	5.5gm	0.19oz
Sensing Geometry	Shear	
Sensing Element Material	PZT-5	
Case Material	Titanium	
Connector Position	0.5m Int. cable with 10/32UNF Microdot Plug	
Case sealing	Hermetic	
Electrical Connection Type	10-32UNF Microdot plug	
Mounting	M6 x 0.75 integral stud	

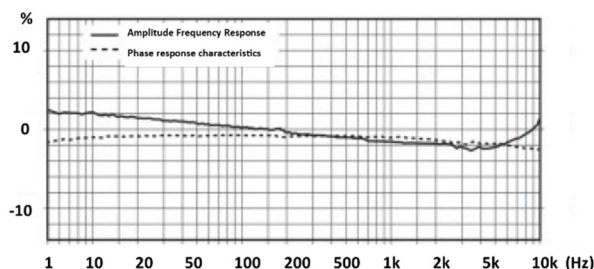
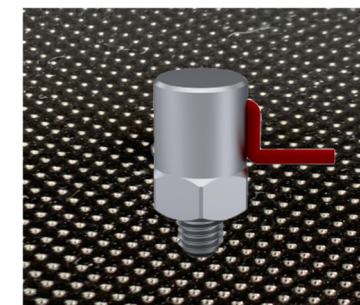
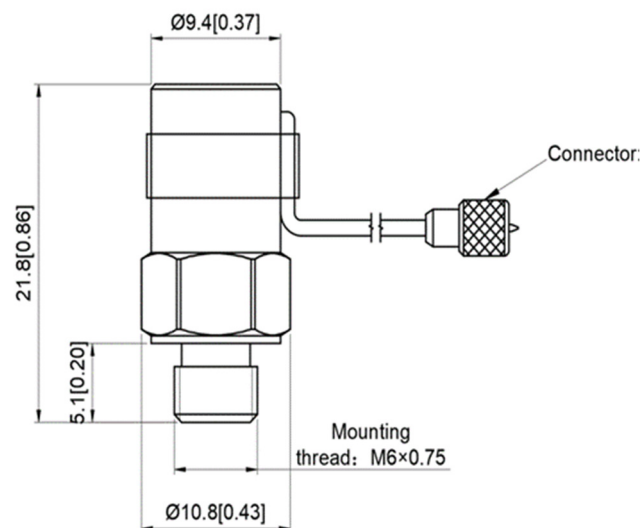

Kemo has a range of cable assemblies available for use with the VS-50K and other IEPE accelerometers.

1B2-30 – 3m(10ft) 10/32UNF microdot to BNC plug  
 1B2-50 – 5m(15ft) 10/32UNF microdot to BNC plug  
 1B1-30 – 3m(10ft) 10/32UNFmdot to 10/32UNFmdot  
 1B1-50 – 5m(15ft) 10/32UNFmdot to 10/32UNFmdot

- Shock IEPE Accelerometer
- Shear design
- Piezoelectric ceramic PZT-5
- Range ±100000g
- Mass – 5.5grams
- 0.5m int. cable with 10/32 Mdot plug
- M6 x 0.75 integral stud

The VS-100K is an IEPE shock accelerometer offering dedicated shock measurement capability. With a ±100000g range the VS-100K combines the flexibility of IEPE (Integrated Electronics Piezoelectric) technology with the reliability of a robust titanium fully welded construction.

Kemo can also offer cables and signal conditioning solutions for use with their full range of accelerometers.

Specification	Metric	Imperial
Sensitivity	0.0051mV/(m/s <sup>2</sup> )	0.05mV/g
Measurement Range (pk)	±980,000m/s <sup>2</sup>	±100000g
Frequency Range ±10%	1 to 10000 Hz	
Resonant Frequency	≥30 kHz	
Non-Linearity	≤1 %	
Transverse Sensitivity	≤5 %	
Overload Limit (Shock)	±1,078,000(m/s <sup>2</sup> )pk	±110000gpk
Operating Temp. Range	-40 to +85°C	-40 to +185°F
Polarity ↑	Positive	
Isolation	Case isolated	
Compliance Voltage (Supply)	+18 to +28 VDC	
Current range	2 – 10mA	
Output Bias Voltage	11VDC ± 1.5VDC	
Output Impedance	≤100Ω	
Size (excluding connector)	10.8mmA/Fx16.7 mm	0.43”A/Fx0.66”
Weight	5.5gm	0.19oz
Sensing Geometry	Shear	
Sensing Element Material	PZT-5	
Case Material	Titanium	
Connector Position	0.5m Int. cable with 10/32UNF Microdot Plug	
Case sealing	Hermetic	
Electrical Connection Type	10-32UNF Microdot plug	
Mounting	M6 x 0.75 integral stud	

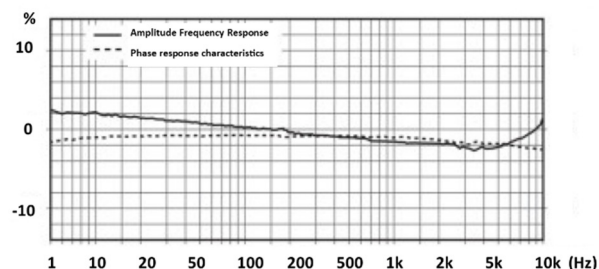
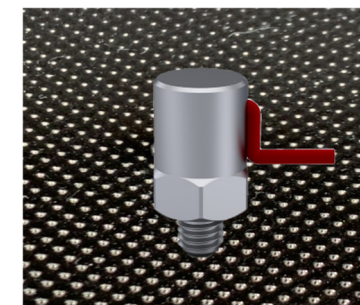
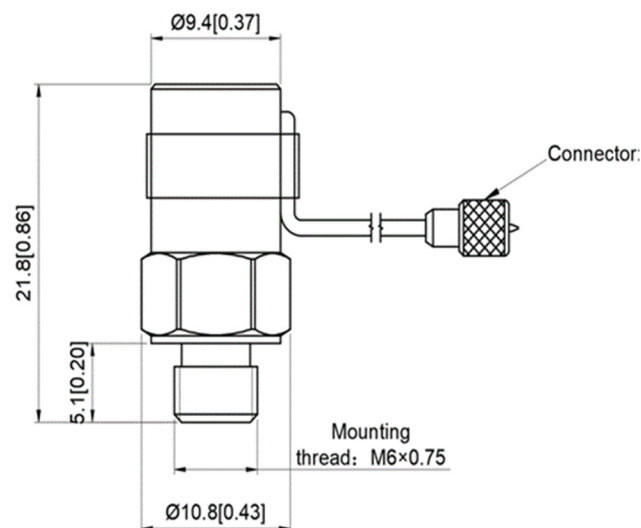

Kemo has a range of cable assemblies available for use with the VS-100K and other IEPE accelerometers.

1B2-30 – 3m(10ft) 10/32UNF microdot to BNC plug  
 1B2-50 – 5m(15ft) 10/32UNF microdot to BNC plug  
 1B1-30 – 3m(10ft) 10/32UNFmdot to 10/32UNFmdot  
 1B1-50 – 5m(15ft) 10/32UNFmdot to 10/32UNFmdot